

**PSM-660  
PUMP STATION  
FLOW MONITOR  
CONTROLLER**

INSTRUCTION MANUAL

**CONTROL ELECTRONICS, INC.**

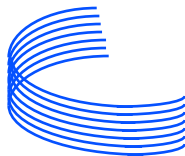

Ship To:  Via UPS

**CONTROL ELECTRONICS, INC.**

148 Brandamore Road  
Brandamore, PA 19316

Mail To: 

**CONTROL ELECTRONICS, INC.**

P.O. Box 330  
Brandamore, PA 19316

Tel: (610) 942-3190

Fax: (610) 942-3672

<http://www.controlelectronics.com> e-mail: [cei@controlelectronics.com](mailto:cei@controlelectronics.com)

# ***INDEX***

<b>SPECIFICATIONS</b> .....	IV.
<b>REPAIR / RETURN POLICY</b> .....	V.
<b>PRODUCT PERFORMANCE STATEMENT</b> .....	VI.
<b>WARRANTY</b> .....	VII.
... Please read first before installing Controller.	
<b>INTRODUCTION</b> .....	1.
<b>GENERAL OVERVIEW</b> .....	2.
<b>INSTALLING THE PUMP MONITOR</b> .....	3.
<b>1. CONTROLLER INSTALLATION</b>	
Enclosure Location .....	3.
Conduit Entrances .....	4.
Enclosure Mounting .....	4.
<b>2. FLOAT INSTALLATION</b>	
If Controlling Pumps .....	5.
Inflow Float .....	5.
<b>3. ELECTRICAL CONNECTIONS</b>	
Floats .....	6.
Contact Closures .....	6.
4-20 mA Input .....	6.
AC Input .....	6.
AC Output / Heater/ Fuse.....	6.
Most Common Setup .....	7.
4-20mA. Outputs.....	8.
Wiring Diagram .....	8.
Relay Outputs .....	9.
DC Volt Outputs .....	10.
RS-232 Output .....	10.
<b>4. ADJUSTMENTS AND CONTROLS</b>	
Reading the 4-20mA Output .....	9.
Float/Contact Closure Configuration .....	11.
SIMULATE Dip Switch .....	11.
Input LED's .....	11.
Relay Output LED's .....	11.
Running LED .....	11.
NO Signal LED .....	11.
DAMP Adjustments .....	11.
4-20mA. adjustments .....	12.
A/D Ref Adjustment .....	12.
ON/OFF switch .....	12.
120/220VAC Select .....	12.
Clk/Mem 3V Battery .....	12.
<b>STARTING UP THE PUMP MONITOR</b> .....	13.
Check List .....	13.
Turning Power ON .....	13.
Viewing The RUN MODES .....	14.

## *INDEX ( CONT'D)*

<b>PROGRAMMING THE MONITOR</b> .....	15.
Pass Code .....	15.
Select Input Type .....	16.
Setting/Testing the 4-20 mA. Outputs ...	16.
Damping Adjustment .....	16.
Relay Outputs ...Alarms .....	17.
Testing Relay Outputs .....	17.
Setting Sequence / Alternation .....	17.
Setting The Time and Date .....	18.
Resetting Pump Hour Meters/Event List	18.
Resetting the Totalizer and Data Log .....	18.
<b>DATA LOGGING</b> .....	19.
24 Hour Summary .....	19.
Viewing Daily Totals .....	19.
Viewing Pump Hour Meters .....	19.
Print Daily Readings .....	19.
Detailed Summary .....	20.
Event List .....	20.
Resetting The Data Log .....	20.
<b>RESETTING THE MONITOR</b> .....	21.
If Flowmeter Locks Up or Crashes .....	21.
<b>USING THE PROGRAM FLOWCHART</b>	
Operating Instructions .....	22.
Power Up Monitor .....	23.
<b>RUN MODES</b> .....	23.
Pass Code .....	23.
Select Input Type .....	23.
Setting <b>PARAMETERS</b> .....	24.
Scale / Set 4-20mA output .....	24.
Sequence / Alternate .....	25.
Alarms .....	25.
Set Communications / Data Log .....	26.
Misc Settings .....	27.
4-20 mA Input Cal Factor .....	27.
Set <b>TIME/DATE</b> .....	27.
Reset <b>TOTALIZER / DATA LOG</b> .....	27.
Reset Pump Hour and Event List .....	27.
Test 4-20 mA. / Relays .....	27.
Viewing the <b>LOGGED</b> Totals .....	28.
Print / Download <b>DATA LOG</b> .....	28.
Display Warnings .....	28.
<b>USING RS-232 COMMUNICATION PORT</b>	
Wiring Connections .....	29.
Saving Download To File .....	29.
Settings For <b>MODEM</b> .....	30.
Settings For Direct To PC COM Port 1 or 2 .....	30.
Using A Serial Printer .....	30.
Initiate <b>DOWNLOAD</b> from a PC or <b>MODEM</b> .....	30.
Download <b>MENU</b> .....	30.

***INDEX ( CONT'D)***

**ILLUSTRATIONS**

General Overview .....	2.
Reading a Chart Recorder .....	9.
3 Volt Battery Installation .....	12.
RS-232 Output Connections .....	29.
FIGURE 1. Enclosure Mounting / Dimensions .....	4.
FIGURE 2. Float Input Connections .....	7.
FIGURE 3. PSM-660 Wiring Diagram .....	8.

**Back of Manual**

RS-232 Serial Printer Connection .....	Drawing 100-05
RS-232 Modem Connection .....	Drawing 100-06
Pump Control connections .....	Drawing 100-07
4-20 mA. Input Configurations	



## Electronics

Power Requirements: 120/220 VAC,  $\pm 15\%$ , 50/60 Hz  
12-24 VDC @ 15W max.

Temperature: 25°F to 120°F (-5°F with opt. heater)

Display: 2 line x 20 character, Alphanumeric, LCD with LED backlighting

Totalizer: 8 digit accumulative with programmable multiplier; x1, x10, x100, x1000  
200 daily, 8 digit totalizers

Outputs: Two (2) independent 4-20 mA isolated into 1000 ohm, RS-232 terminal and RJ11 modular jack, 5 relays - 3 control and 2 Alarm (low - high), SPDT 5A/250 VAC contacts

Flow Range: 0-100,000 GPM

Display Resolution: 0.01", 0.01 gal/min

Accuracy\*:  $\pm 1.0$  second run time,  $\pm 0.1\%$  calculation error

Memory: Flash and non-volatile RAM

Data Log: **200 day 24 hour summary:** # of cycles, total run time, avg GPM, total gallons;  
**Detailed summary of pump cycle:** pump#, cycle#, start and run time, inflow GPM rate, pump GPM rate, total pumped.  
**Event List** time stamped.

## Enclosure

Material: Fiberglass with clear hinged Polycarbonate cover

Rating: NEMA 4X, IP65, Dust-Tight, Water-Tight, Corrosion Resistant, CSA, UL listed

Dimensions: 7.2"x11.8"x6.8"

Mounting: 4.92"x12.3" with stainless steel mounting feet

## Inputs

Floats and/or Contact Closures (optically coupled), 4-20 mA.

## Options

Heater/Thermostat, Clamp ON Current Sensor, Modem ....

Warranty: the PSM-660 system is pretested and inspected before shipping. Warranty is against defects in parts and workmanship for a period of one (1) year from ship date.

\* Note: field conditions, such as turbulence, poor installation etc., may affect the apparent accuracy.

Specifications and design subject to change without notice.  
Made in USA.

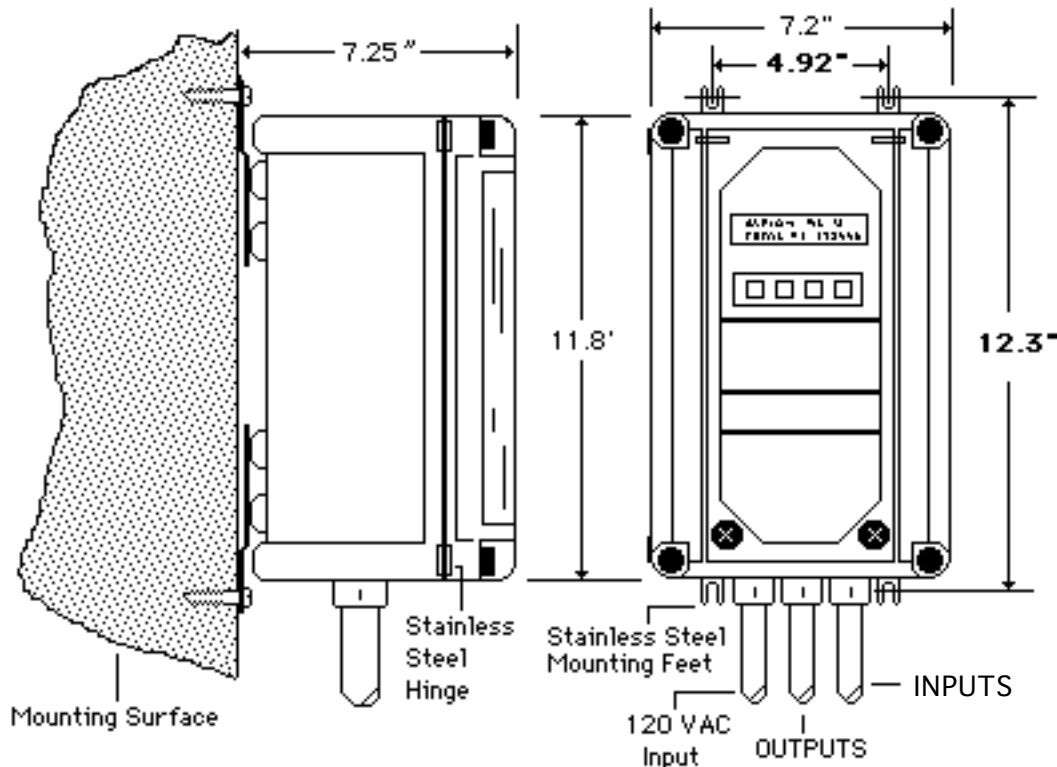

Enclosure Dimensions

**Repair Policy:** All repairs are performed on our premises. Repairs must be sent to Control Electronics by UPS prepaid. Customer must enclose a description of problem, who to contact, phone number, return ship-to address and **purchase order number** to cover repairs. Delay of repair may occur if information is not provided. No ARM number is required. Most repairs are processed within 48 hours unless major repair is required.

**Repair Cost:** A minimal charge will be applied regardless of repair needed plus return shipping charges. If repair exceeds quoted minimal charge, we will notify the customer before we proceed.  
**Payment is COD or Credit Card only** unless other arrangements are made.



Warranty repairs are made at our discretion and returned UPS GROUND at our expense.

**Return Policy:**  
(within 6 months) Control Electronics will accept 'return of product' for credit within 6 months of shipping date if it is determined that the product is not performing to specification as described in Product Performance statement in this manual (provided application is not the cause of problem). We do not accept returns for credit when the application is the source of the problem (i.e. poorly installed flumes, poor piping arrangements, interference from other equipment etc.) , product is misapplied or not used properly and/or if product is out of warranty (12 months from ship date).

(after 6 months) A **35% restocking charge** will be applied if product is returned for credit after 6 months from ship date. ( 7 to 12th month from shipping date).

Control Electronics does not accept returns of options such as circular recorders and other products not manufactured by Control electronics, Inc.

Control Electronics will not accept returns of used Sensors, cables, or spare parts unless shown to be defective under warranty or not performing as specified.

Any credit issued will be at the discretion of Control Electronics, Inc. Warranty of product is limited only to the repair or replacement (with same model) of defective product.

Any product or part of product returned damaged will not be considered for any credit.

**Customer must call for authorization before returning product for credit.  
Products returned for credit will not be considered without prior authorization.**

A description of how it was determined that the product was not performing to specification must accompany the return of the product for our evaluation before Control Electronics will consider any credit. The name of who to contact along with phone number should also be included with the return.

**Ship To Adress:** All repairs or returns must be shipped prepaid via UPS or equal to:  
Control Electronics, Inc., 148 Brandamore Rd., Brandamore, PA 19316

## **CONTROL ELECTRONICS, INC.**

### **PSM-660 Product Performance**

Control Electronics PSM-660 Series will perform as specified when tested under known, simulated conditions. All PSM-660's are tested for full functionality and performance before shipping.

The **accuracy** of the product is determined by inputting known elevation points and monitoring its ability to process the information accurately. Specifications for the product are determined by this method.

The **accuracy** of the product is not determined by wet-well draw-down test, pump curve charts etc. Such test indicate the accuracy of the over-all application/installation of floats, elevation measurements, displaced liquid by hardware etc., not just that of the product. Such tests are not acceptable as an indication of 'product(s) accuracy'. However, draw-down test etc. can be used to determine if the calibration of the product should be changed to compensate for application and installation conditions. This should only be done if no other application or installation corrections can be initiated to correct the problem.

Some equipment such as variable speed drives, nearby radio transmitters (i.e.: radio dispatch or hand held transmitters) etc. located next to the product or even at times in adjacent rooms may interfere with the products performance. The worst of these is usually the variable speed drive controllers. This type of equipment generates large amounts of electrical and RF (radio frequency) noise that can interfere with the products processing of data and may cause a software crash. Relocation of the product or different electrical grounding attempts may minimize or eliminate the interference. Ultimately, it is up to the user to make the corrections necessary and require that the product that is causing the interference be corrected.

If you have any questions in regards to product performance, please contact Control Electronics at (610) 942-3190 or fax us with application conditions and questions at (610) 942-3672. You may also e-mail us at: [cei@controlelectronics.com](mailto:cei@controlelectronics.com).

# CONTROL ELECTRONICS, INC.

## PRODUCT WARRANTY

### **WARRANTY:**

Control Electronics, Inc. warrants to the buyer that its products are free from defects in materials and workmanship at the time of shipment and during the WARRANTY PERIOD. Control Electronics, Inc. obligation under this warranty is limited to the replacement of the product(s) by same product(s) manufactured by Control Electronics, Inc. or repair of the product(s) at the Control Electronics, Inc. facility. Control Electronics, Inc. products are sold with the understanding that the buyer has determined the applicability of the product(s) to its intended use. It is the responsibility of the buyer to verify acceptability of performance to the actual conditions of use. Performance may vary depending upon these actual conditions.

This Warranty is in lieu of any other warranty, expressed or implied. This includes, but is not limited to, any implied warranty of fitness for a particular purpose, or other obligations or liabilities on the part of Control Electronics, Inc. Under no circumstances will Control Electronics, Inc. be liable for any loss, damage, expense, or consequential damages of any kind arising in connection with the use, or inability for use, of Control Electronics, Inc. products.

### **WARRANTY PERIOD:**

This warranty is in effect for twelve (12) months from the date of shipment from Control Electronics, Inc. place of business. Any extension of warranty period must be requested at time of purchase and made part of purchase order.

### **LIMITATIONS:**

Control Electronics, Inc. products must be installed and maintained in accordance with Control Electronics, Inc. published instructions. Users are responsible for the suitability of the product(s) to their application. There is no warranty against damage resulting from corrosion, misapplication, improper specification, improper installation or any conditions beyond the control of Control Electronics, Inc. Claims against carriers for damage in transit must be filed by the buyer. Control Electronics, Inc. is not liable for labor costs incurred in removal, reinstallation, or unauthorized repair of its product(s). Control Electronics, Inc. warranty does not cover travel time or expenses for job site service. Requests for field service must be accompanied by a signed purchase order. Travel time and expenses will be charged to this purchase order, along with service time if the cause of the failure is not covered by the warranty. No service will be performed on any product(s) unless full payment has been made for product(s).

### **WARRANTY CLAIM:**

If Control Electronics, Inc. products are found to be defective in materials or workmanship within twelve (12) months of the date of shipment, they will be repaired or replaced with same product at the discretion of Control Electronics, Inc. at its place of business at no charge to the buyer. The defective product(s) must be sent, freight prepaid, to the ship-to address on the front page of this manual for warranty claim. All claims must be made in writing. Enclose a brief description of problem, person to contact, phone number and return ship-to address. Product(s) received without this information may not be processed on a timely basis.

**If warranty and/or product(s) is not acceptable to buyer, please contact Control Electronics, Inc. and/or return product(s) unused for credit. This action must be made within 60 days from ship date from Control Electronics, Inc. Installation of product(s) or non-response within 60 day period indicates the buyers acceptance of product(s) and above warranty.**

## NOTE

You may want to copy the following numbers from the upper left corner of the printed circuit board inside the enclosure for future reference. These numbers should be available if calling Control Electronics for tech support.

Serial Number: \_\_\_\_\_

Software Version: \_\_\_\_\_

Model Number: \_\_\_\_\_

# INTRODUCTION

Control Electronics model PSM-660 Pump Station Flow Monitor Controller is a microprocessor based system, designed to control up to 4 pumps with sequence and alternating capabilities and also to accurately measure liquid flow volume throughput in a wet well/lift station application. The system monitors floats, auxiliary control contacts or 4-20mA. input to control the pumps and calculate the volume throughput.

The PSM-660 Monitor has been designed with the user in mind, allowing for simple, intuitive setup through a menu driven programming interface. The operator will first select the type of input ( floats/contact closure or 4-20mA ) that the Monitor will use. The operator then enters dimensions of the wet well and pump ON/OFF elevation points to calculate a known volume to be pumped from the wet well. With the addition of an intermediate float switch/elevation point, the pump monitor will calculate the inflow GPM rate just prior to the start of the pump cycle. If no inflow float or elevation point is to be used, the Monitor will use the fill time of the known volume to calculate an average GPM inflow rate. The inflow value is then applied to the known volume pumped in calculating the total volume throughput for the pump cycle. The final accuracy of the PSM-660 is equal to a precise 'draw-down' test performed on each pump cycle. The Monitor may also be programmed to compensate for displaced liquid volume caused by piping and other hardware in the wet well.

All PSM-660 circuits are protected in a NEMA 4 X, IP65 corrosion resistant fiberglass enclosure with a clear polycarbonate hinged cover for easy viewing of flow and programmed data.

After installing the Pump Station Monitor, the operator will find the PSM-660 programming Flowchart in the back of this manual extremely helpful in navigating through the many options and features of the system.

With proper understanding of how the Pump Monitor works and its' successful installation, the PSM-660 will provide the user with many years of continuous, reliable operation.

## IMPORTANT NOTICE

**It is STRONGLY RECOMMENDED that the user install back-up floats or other methods for LOW and HIGH level sensing in the wet well in the event there is a failure of the PSM-660 system when controlling pumps.**

**Control Electronics, Inc. does not assume any responsibility or liability of problems or damages resulting from a failed system. It is the responsibility of the user to provide backups in critical applications.**

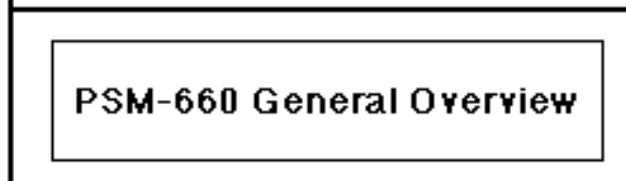
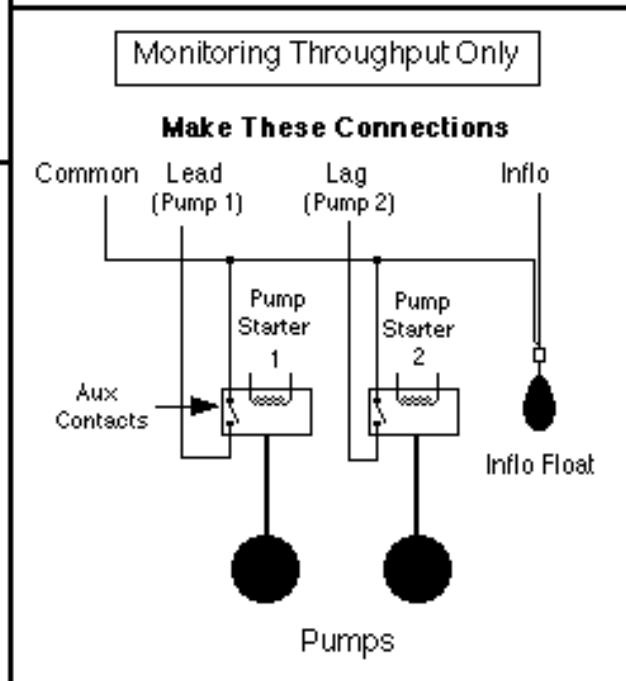
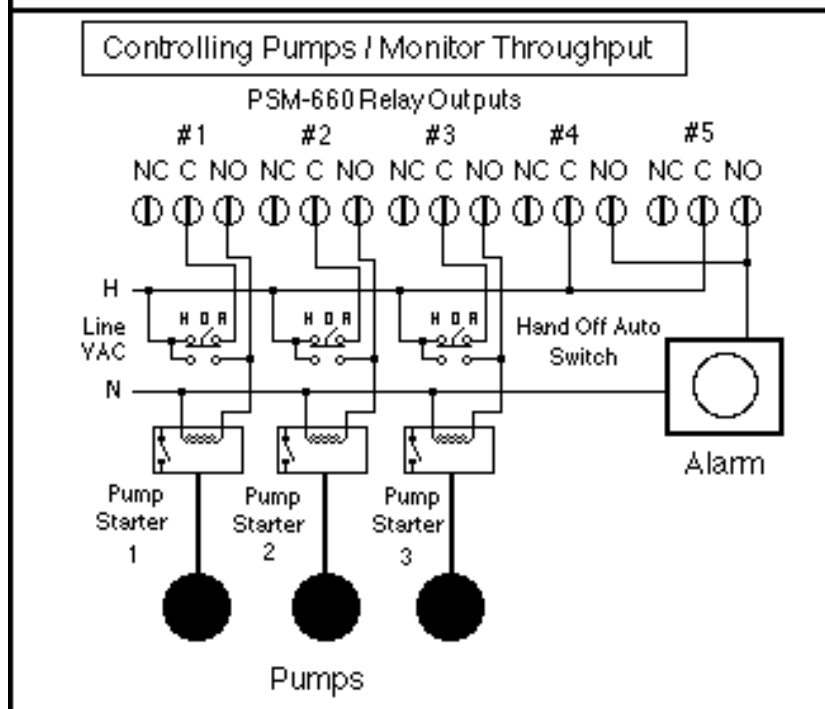
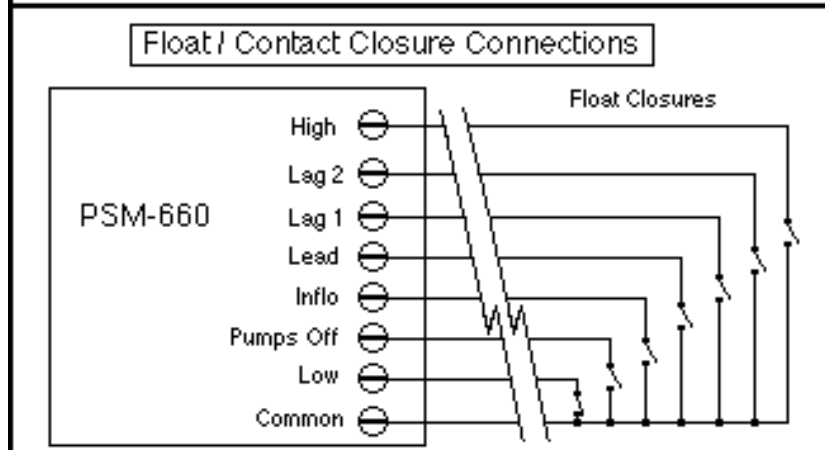
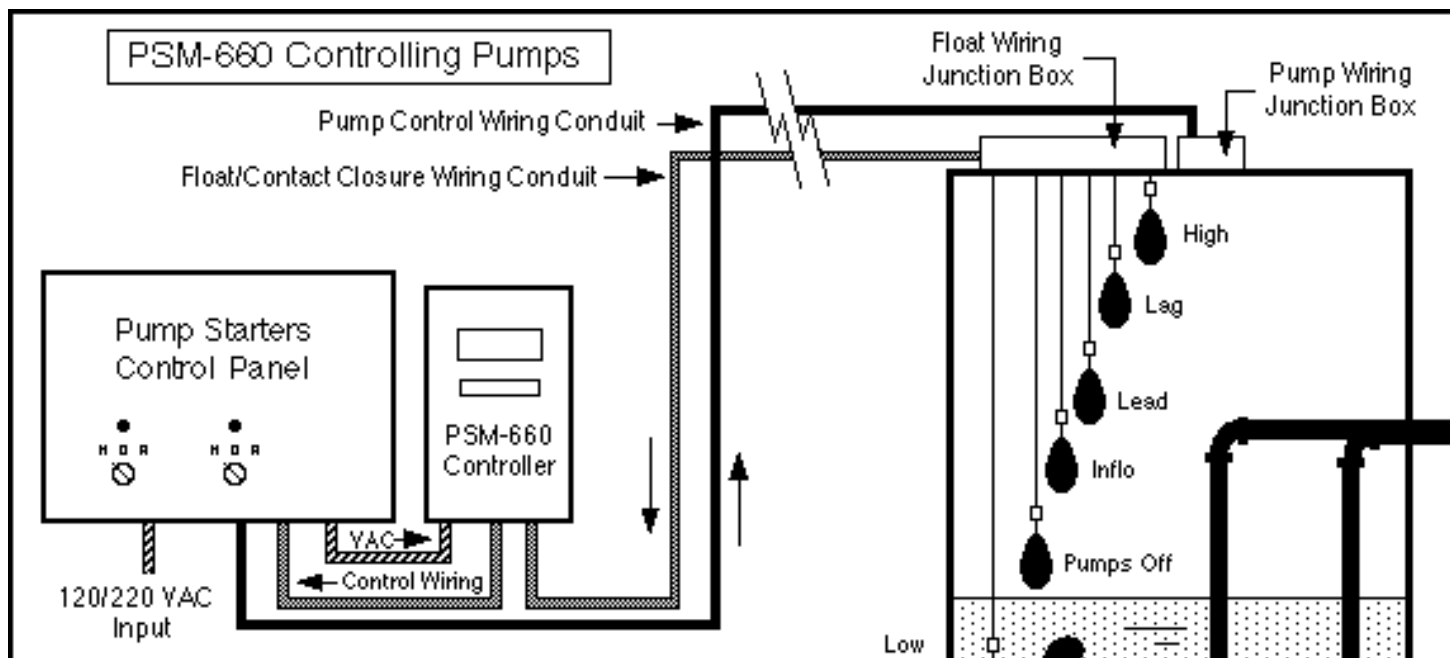

# INSTALLING THE PUMP MONITOR

The PSM-660 Pump Monitoring system is easy to install. Adherence to all installation instructions will result in successful operation of your system. If any deviation must be made from the prescribed installation procedures, please call our service department for change approval. Failure to install your system properly could lead to operational problems and become costly if a service technician is required on-site to remedy. **We suggest you read the manual first to familiarize yourself with the equipment before installing.**

## 1. CONTROLLER INSTALLATION

The PSM-660 electronic controller is housed in a NEMA 4X, IP65 fiberglass enclosure. This enclosure is UL listed and rated as being water-tight, dust-tight and corrosion resistant. However, care should be taken in selecting a location that will offer protection from rain, chemical spills, extreme temperatures etc.

The electronics enclosure is suitable for outdoor installation, but it is recommended that the enclosure be mounted indoors or in a fiberglass shed or control panel located next to the measuring site. If the unit has to be located outdoors, provisions should be made to maintain a temperature range between 25°F and 120°F within the enclosure. For cold locations, our optional Heater and Thermostat should be purchased. This option can be installed at any time by the user. The enclosure should also be mounted away from direct sunlight or a sun shade should be provided.

### IMPORTANT

*On a hot day, direct sun light could damage the LCD display and raise the internal temperature of the enclosure well above ambient temperature causing malfunction and/or possible damage to the unit. Use a sun shade if direct sun light can not be avoided.*

The PSM-660 Electronics requires a 120/220 VAC power source. Though the PSM-660 Monitor is designed to tolerate external electrical interference you should avoid installation in locations near equipment that may be electrically noisy or instruments that generate R.F. (radio frequency) noise such as SCR controlled equipment (i.e. variable speed controllers). This will minimize any potential problems.

The enclosure must be located so float wiring or auxiliary contact closure connecting points are accessible to the PSM-660. The inputs to the PSM-660 are low voltage, opto-isolated inputs. **Float and contact closures must be non-powered and used only by the PSM-660.**

Once a suitable location has been selected for the controller, carefully screw mount the enclosure as shown in figure 1. Be sure to leave room for conduit entrance to the enclosure as shown.

All conduit entrances should be made through the bottom side of the enclosure. **Do not enter through the top.** This could cause possible water damage from leaks if the enclosure is rained on or hosed down. Separate conduits should be provided for 120VAC power source (conduit not required if supplied with optional AC power cord), output signal wires (4-20 mA., relay outputs etc.) and input wiring ( floats, 4-20mA. etc.).

**IMPORTANT**

*All Conduit entrances must be made water-tight to maintain the enclosures NEMA 4X rating. This may include plugging the conduit after pulling wires with electricians putty to prevent gas and condensation migration. Failure to make water-tight entrances may void warranty.*

Use care to protect the electronics circuit card from damage when punching or drilling holes in the enclosure for conduit entrance. The circuit card may be removed from the enclosure by removing the four retaining screws (M1~4 , top and bottom edge of board) and unplugging the ribbon cable. A GREENLEE punch is recommended for punching the holes.

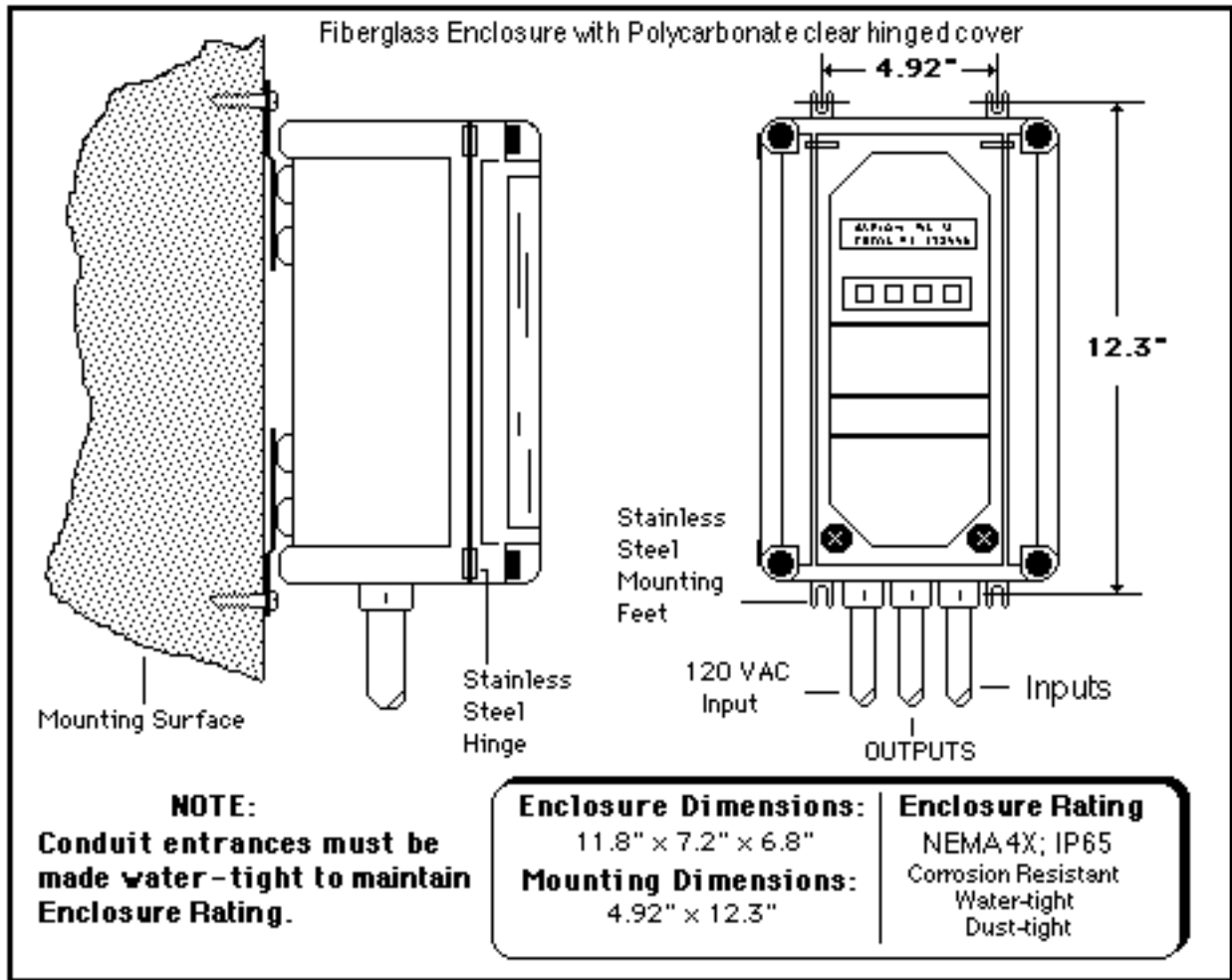

Figure 1.

## Enclosure Installation In General....

- 1] Mount enclosure in a suitable location as described above. DO NOT locate in a confined or hard to reach area.
- 2] All conduit/wire entrances should be made at bottom of enclosure.
- 3] Conduit/wire entrances should be watertight to maintain enclosure rating.
- 4] Do Not mount enclosure in direct sun light. This could overheat the unit on hot days. A sun shade should be considered.

## 2. FLOAT INSTALLATION

*Note: if using a 4-20mA. input from a pressure sensor or other source, no floats are needed. Proceed to ELECTRICAL CONNECTIONS.*

### *Floats (if controlling the pumps)*

Using Float inputs is only necessary if you are controlling the pumps with the PSM-660 unit. The Float locations in the wet well is the most important consideration for proper operation of your Pump Monitor. The Floats (either existing or new) should be located in the wet well away from the fill pipe, its drop splash and hardware that may entangle them ( ladders, piping etc. ). The floats should be suspended from or attached to supports securely so they will not unknowingly slip, changing the floats activation point. Different methods of supporting the floats are possible and it is up to the user to choose the best method for their application.

The elevations of the floats should be known as precisely as possible. It is best to know the elevation at which they activate, not necessarily their 'free-hanging' elevations. Calibration inaccuracies may arise from incorrect measurement of float elevations. Elevation points will be needed for programming the PSM-660 Monitor later.

### *Inflow Float (optional)*

To monitor the inflow rate into the wet well, it will be necessary to install and connect one float (or use an existing spare float) to the PSM-660 input labeled 'InFlo'. This float is usually installed approximately 6 to 12 inches lower than the LEAD ON float. The inflow float is used to calculate GPM inflow rate prior to pumps coming on. The elevation of the float will be needed for programming later. If no INFLOW float is used, the system will monitor the fill time of the wet well and calculate an average GPM inflow rate. Selection of inflow type method used will be set by the user in the systems program section. 'No Inflow Float' is the default setting.

### 3. ELECTRICAL CONNECTIONS

*Note: when making connections to the terminal barrier strip on the circuit board, do not over-tighten the wire set screws. You may damage the terminal barrier.*

#### *Floats (controlling the pumps)*

All float electrical connections should be made with wire nuts and electrical tape. Hard to reach areas should be avoided. All splices should be in a clean, dry junction box that is easily accessible at the top of the wet well. Wiring should be pulled through a conduit back to the PSM-660 controller. Use wire size 16 gauge or smaller. The float inputs to the PSM-660 operate with low voltage/current. Connections of the floats should be made to the circuit board labeled TB3 (terminal barrier 3) Float inputs as per type of control you are expecting the PSM-660 to do. Refer to the PSM-660 Input wiring diagrams.

#### *Contact Closures (when monitoring volume only)*

If you are using the PSM-660 unit to monitor volume throughput only (i.e. the PSM-660 is not controlling the pumps) and want to monitor each pumps run times and volume pumped ( i.e. data log ), you must connect LEAD (pump 1) and LAG 1 (pump 2) to the pump starters auxiliary contact closures to the float inputs on the circuit board labeled TB3 (terminal barrier 3). if you are not using the data log features, the PSM-660 may be connected to an auxillary contact closure that addresses only the LEAD pump 'ON'. This allows the system to monitor the volume pumped from the wet well while another system controls the operation of the pumps. If no auxiliary contact closures are available, it may be necessary to provide a relay in parallel with the pump starter or use our optional clamp on current sensor to supply the needed contact closure.

#### *4-20 mA. Input (controlling the pumps)*

If you are using a 4-20mA input from a pressure sensor or other level device, make your connections to the circuit board labeled TB3, '4-20ma Input'. Make sure to observe polarity. When using a 4-20 mA input, the float inputs are disabled. When programming the Monitor you will need to select the **INPUT TYPE** when asked. The elevation values in inches for 4 mA and 20 mA will also be needed to scale the input. See back of manual for INPUT CONFIGURATIONS.

#### *AC Input*

120 VAC power (220 VAC if jumper selection is made for 220 VAC operation. See circuit board diagram for jumper location) must enter through the bottom side of the enclosure in its own conduit. Connect AC power to the terminal barrier strip at the bottom left of the electronics card marked AC INPUT. DO NOT allow the AC wires to lay all about in the enclosure. 14 gauge wire is preferred over a heavier wire that may place unnecessary stress on the terminal barrier.

#### *AC Out*

This output provides a switched 120 VAC power to the optional heater/thermostat for cold climates or to control an external recorder or other device that operates in conjunction with the Monitor. Note: 220 VAC heater is not available.

**Note:** the PSM-660 uses a .5 amp fuse. It may be necessary to increase fuse rating to 1 amp to accommodate external devices. Max rating should not exceed 3 amps.

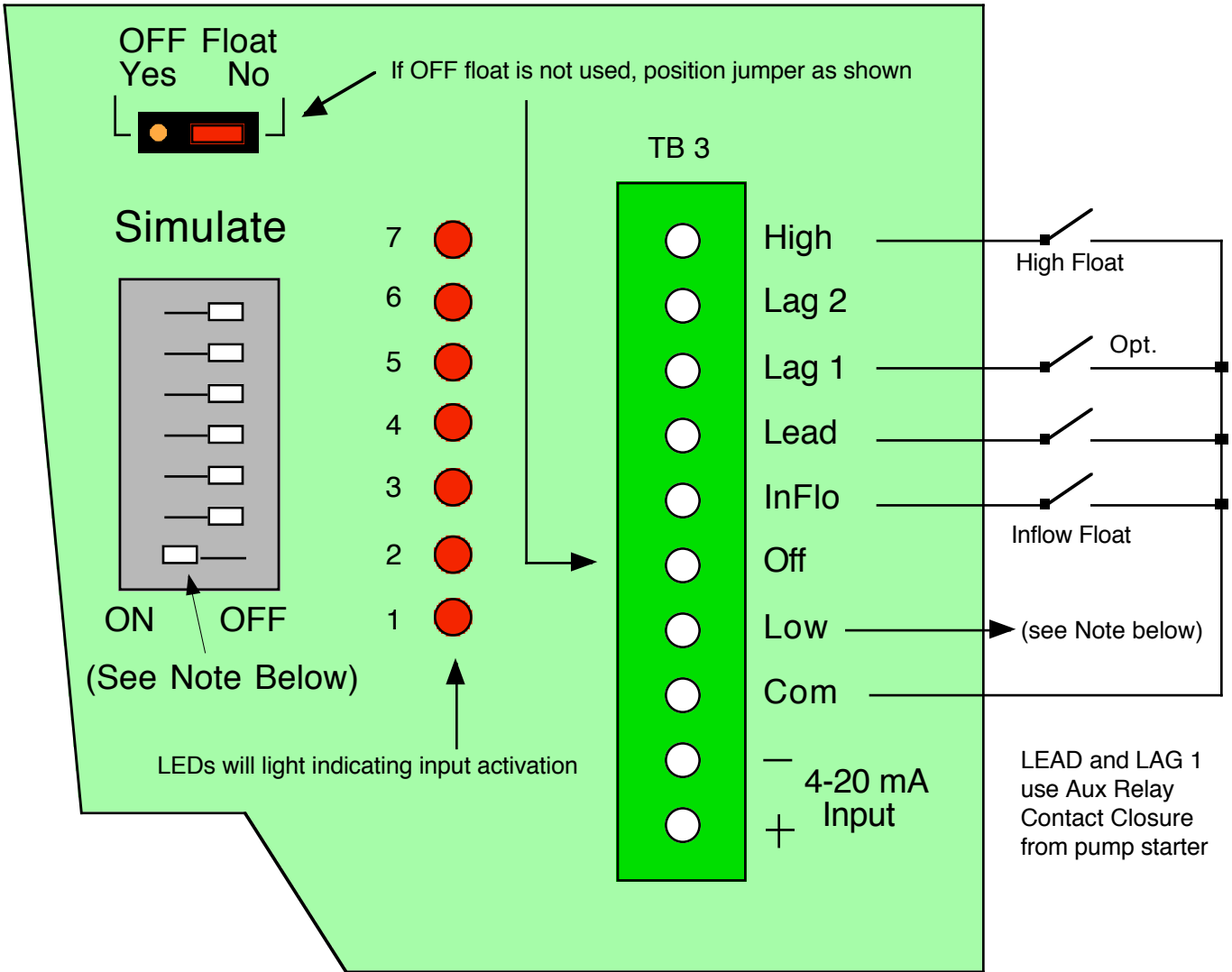

### Most Common Setup

This setup will Monitor VOLUME THROUGHPUT Only. LEAD (pump 1) and LAG 1(pump 2) are controlled by auxillary relay contact closures from pump starters. Using the InFlo input is optional. See programming. HIGH input float is also optional, but recommended.

**Note: the SIMULATE input LOW must be switched to 'ON' position if no LOW float is used. Low float would normally maintain a contact closure until the level drops below LOW float.**

OFF, LEAD and LAG 1 inputs can use float inputs instead of the Aux Relay inputs to control the pumps.

Figure 2, Connecting The Inputs

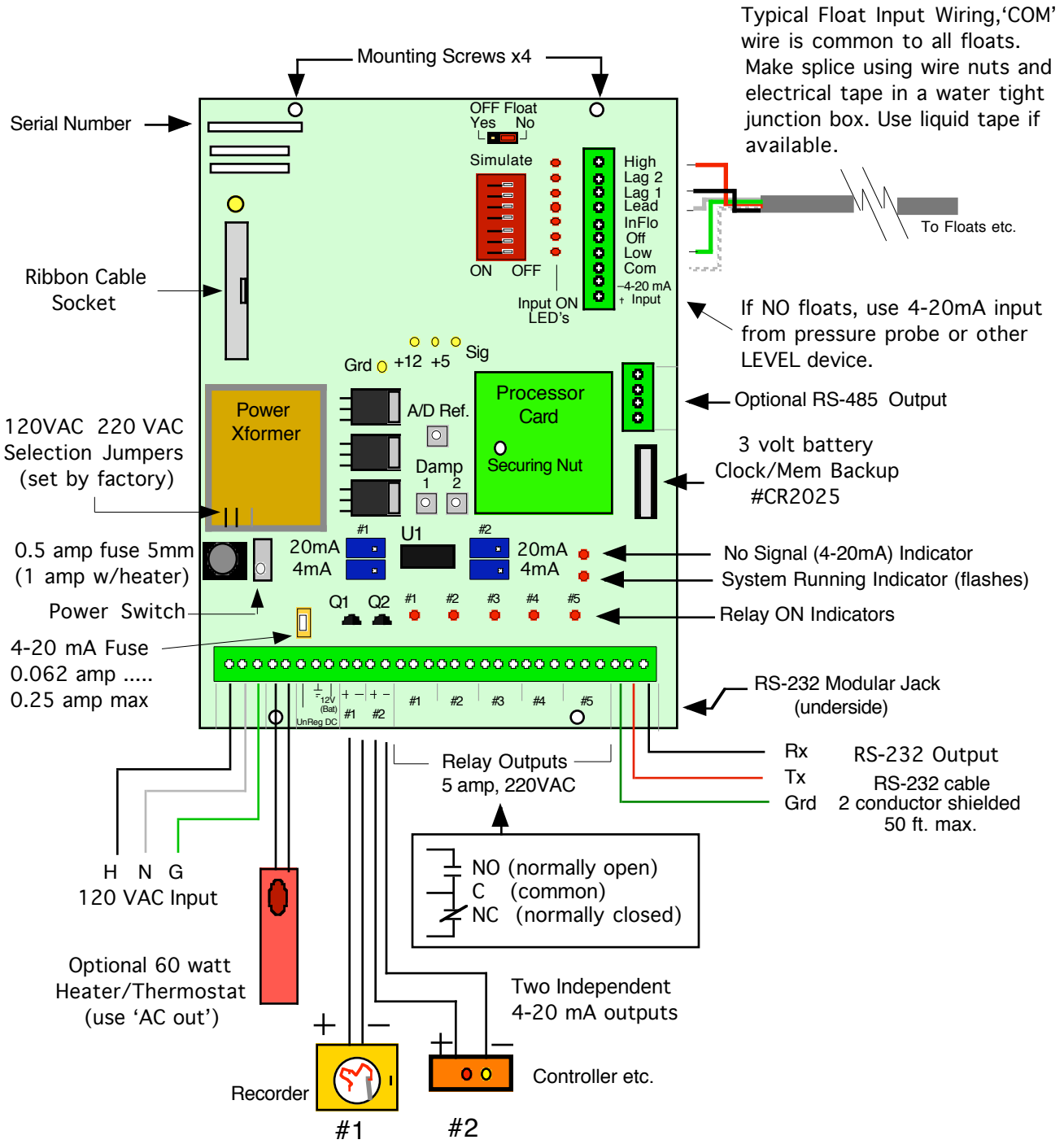

## PSM-660 Wiring Interconnect Diagram

Figure 3.

### 4-20 mA Outputs

The PSM-660 has two (2) 4-20 mA outputs independently programmable . Each output will drive a 1000 ohm loop resistance.

The 4-20 mA. analog output signals are FLOATING outputs ( both the '+' and '-' terminals have their potential above system ground) and are DC isolated. Use any standard twisted pair shielded cable to make connections, Belden#8451 or equal. Polarity must be observed through the entire control loop for proper operation. The ground return of the cable, if used, must only be connected at one end. Either to ground ( $\perp$ ) on the PSM-660 unit or ground to receivers input.

### Reading the Chart Recorder

Under **SET PARAMETERS ... SET 4-20mA output as**, see Flowchart #2

**select 4-20mA output as GPM PUMP RATE**

the Analog outputs (i.e. 4-20 mA outputs) indicate the previous pump cycles avg. GPM pump rate and the present (this cycles) RUN TIME . Reason is, the pump monitor does not know the pumping rate until the pump cycle is complete. So remember, when you analyze a circular chart recording, the information recorded is showing the GPM rate for the previous cycle and the 'pump run time' for this cycle.

**select 4-20mA output as LEVEL**

If floats are used, the recorder will record the floats elevation value and ON time. If 4-20mA input is used, the recorder reflects the Level input value.

**select 4-20mA output as AVERAGE GPM INFLOW RATE**

The chart recorder will indicate the average INFLOW GPM RATE between pump cycles.

Note: Output #1 is in GPM. #2 may be set for GPM, LEVEL or INFLO

This cycles RUN TIME  
Previous cycles GPM

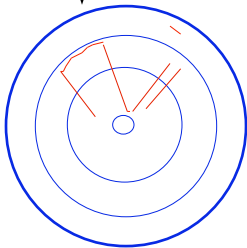

Chart Recorder Indicating  
RUN TIME and GPM rate  
Select 4-20mA output is GPM

Each level represent float or 4-20mA  
input elevation points

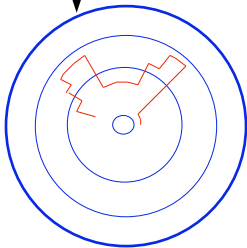
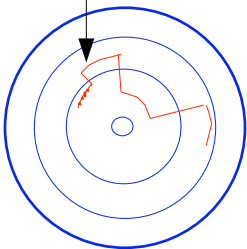

Chart Recorder Indicating  
when each float or contact closure activates  
Select 4-20mA output is LEVEL

Average GPM INFLOW RATE  
between pump cycles



Select 4-20 mA output is INFLOW RATE

## Relay Outputs .... ALARMS

### When using FLOAT or CONTACT CLOSURE inputs.

Relay 1, 2 and 3 are used to control pumps or other external devices. Relay 1 is considered the LEAD (pump 1) control, Relay 2 is LAG 1 (pump 2) and Relay 3 is LAG 2 (pump 3). The sequence order can be modified in the programming so Relay 2 is made the LEAD pump etc. The assigned LEAD and LAG 1 outputs may also be programmed to alternate. LAG 2 is used to control a third pump. Relay 4 is LOW ALARM and relay 5 is HIGH ALARM. LOW ALARM will be removed when pumping begins. HIGH ALARM will be removed when pumps stop. LOW ALARM turns all pumps OFF. HIGH ALARM starts pump 1 & 2.

LED's 1 thru 5 will light accordingly when relay is activated.

### When using 4-20 mA. inputs.

Relay #4 output is used for 4th pump (LAG 3) or as a HIGH ALARM. Relay 5 is ALARM output and be set as a LOW or HIGH alarm.

 **Note:** pressing any keypad button will silence the alarm (turn alarm relay OFF).

### IMPORTANT

*All relay contacts are rated 5 amp 220VAC. Wiring to the contacts should be capable of handling the load applied. Consider providing a circuit breaker so max current rating of contacts is not exceeded. Also, a SNUBER connected across the contacts will extend the life of the contacts.*

## DC Volts Output (unreg, +12VDC, +24 VDC)

These inputs/outputs provide DC power for optional accessories or allow for battery operation of the controller. UNREG DC is both an input and an output. When AC power is applied to unit, an unregulated voltage of approximately 16~18 VDC will be found at this point between UNREG DC and GROUND (  $\perp$  ) and 12 VDC between 12VDC and GROUND. 24 VDC is available between '+' of the 4-20mA output and ground (  $\perp$  ). This may be used to power customer options. Max current draw should not exceed 150 mA.

Note: 4-20 mA fuse may need to be increased to a maximum of 250 mA.

## RS-232 Output

An RS-232 output is available on the terminal barrier labeled ' $\perp$ ' (ground), Tx (transmit) and Rx (receive). A twisted pair shielded cable, Belden# 8451 or equal, should be used, maximum of 50 feet. See USING RS-232 OUTPUT, page 31.

## 4. ADJUSTMENTS AND CONTROLS

### *Float / Contact Closure Input Configuration*

After connecting the needed floats / contact closures to the input terminal barrier TB 3, you need to check for 2 possible configurations. See figure 2, page 7.

- 1] If you are not using an 'OFF' float, you must position the 'OFF Float' jumper, located above the SIMULATE dip switches, to the 'NO' position (this is the default setting). If an 'OFF' float is being used, move the jumper to the 'YES' position. An 'OFF' float is used only when controlling the pumps with the PSM-660 unit.
- 2] If you are not using a 'LOW' float, you must position the SIMULATE 'LOW' Dip Switch to the ON position, LED 1 will light (default setting). If using a 'LOW' float, turn this Dip Switch OFF.

### *SIMULATE Dip Switch*

The SIMULATE Dip Switch is used only when monitoring float/contact closure inputs. The SIMULATE switches allow the user to simulate inputs for test purposes. They should be used in the proper sequence order as if the floats are sensing the rise or fall of the level.

Example: INFLO should be done before LEAD; LEAD before LAG1 etc.

### *Input LED's*

LED's 1 thru 7 will light when the associated input is active.

### *Relay Output LED's*

LED's 1 thru 5 will light when the associated relay is energized. Relay 1,2 and 3 are used for pump control; Relay 4 for LOW alarm and Relay 5 for HIGH Alarm.

Note: When using 4-20 mA. input, relay 4 is for 4th pump (LAG 3 ) or HIGH alarm. Relay 5 may be set for HIGH or LOW alarm.

### *Running LED*

Each time the system makes a measurement, this LED will flash. Typical rate is 4 times per second. This is considered normal operation and should be flashing steadily.

Note: when downloading data log this LED will appear erratic. When using a 4-20 mA input, the flash rate may vary between 2 and 4 times a second.

### *No Signal LED*

The NO SIGNAL LED should be OFF under normal operation. When using the 4-20mA input for LEVEL, the LED should light if the 4-20 mA input signal is lost. A warning will be written on the LCD display.

### *4-20 mA. DAMPING*

Adjust clockwise to increase the 4-20 mA. Analog Output Dampening for steadier chart recordings.

### 4 mA.

The 4 mA. adjustment is used to set the 4-20 mA. current output loop to 4 mA. This should be set before the 20 mA. adjustment. This will prevent any apparent interaction of the 4 and 20 mA. adjustments. You can Simulate 0% output (4 mA) using the **TEST 4-20 mA OUTPUT** feature under **MISC Settings ?** mode in the programming to set the 4 mA. output. Outputs #1 and #2 may be adjusted at this time. Note: output 1 and 2 are independent and have no affect on each other when adjustments are made.

### 20 mA.

Adjust the 20 mA. control for 20 mA. output on the 4-20 mA. current output loop. Simulate 100% output using the **TEST 4-20 mA OUTPUT** feature found under **MISC Settings?** mode in the programming. Note: output 1 and 2 are independent and have no affect on each other when adjustments are made.

### A/D REF

This sets the reference voltage for the A/D converter which measures the 4-20 mA input when used. INPUT milli-amp value can be viewed under **MISC SETTINGS** in programming. Adjust the A/D REF, enter a CAL FACTOR (preferred, See FLOWCHART #5.) or adjust source to make corrections.

### ON/OFF Switch

Applies AC power to the circuit board and the AC OUT.

### 120/220 VAC

Install or remove appropriate jumper(s) to change operating voltage to 120 or 220 VAC. Note: this is factory set. Jumpers are located under left-bottom corner of power transformer.

### CLK/MEM 3V Bat

This battery is for retaining programmed information and keeping the clock running when power is turned OFF. The battery should last for approximately 8 to 10 years under normal operation. You may replace the battery when power is ON by pulling the battery out of its holder and replacing it with a '#CR2025' 3 volt lithium battery or equivalent.

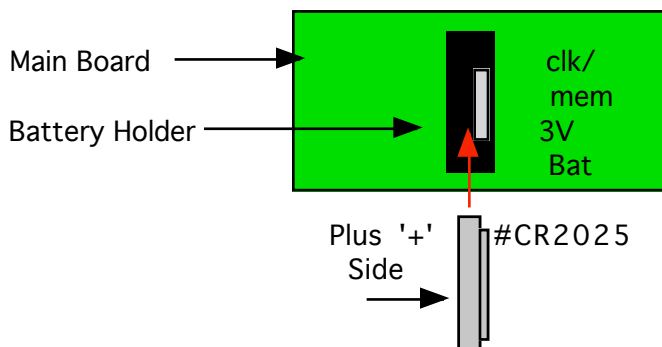

### WARNING!

Install Battery Observing Correct Polarity.

If battery is removed when power is 'OFF', all programming and clock/date will be lost. You will need to restart system as described in the programming Flowchart #1 using the 'SHIFT' button to RESET the meter to defaults and then reprogram.

# **STARTING UP THE PUMP MONITOR**

Once all installation procedures have been completed, the PSM-660 Pump Station Monitor is ready to be powered up. But before doing so, it is advisable that you go back and check your installation to ...

## **Before Applying Power Quick Check List**

- 1] confirm that all wire connections are correct and secure, particularly the AC power input with correct circuit breaker size.
- 2] confirm that the floats (if used) have been installed properly and any splices made are correct, secure and moisture tight ( use liquid tape, available at most electrical and hardware stores).
- 3] make sure all conduit entrances to the enclosure are watertight. Use electricians putty to plug conduits to prevent condensation and gases migrating to enclosure.
- 4] measure the float elevation points (where they activate) in inches. You will need these values when programming.

You are now ready to power up the system.

### **TURNING POWER ON**

 Please note: It is best to apply power to the Monitor after the wet well has completed a pump cycle. This will allow time to program the unit before the next cycle begins.

Turn AC power Circuit Breaker ON back at the electrical panel if needed. Switch the POWER ON to the Monitor by switching the small toggle switch on the lower left of the main circuit board to ON.

Once power is applied, the Monitor will power up and display a few banners indicating manufacturer and software revision number. Before shipping, the Monitor was set to factory defaults and should now display...

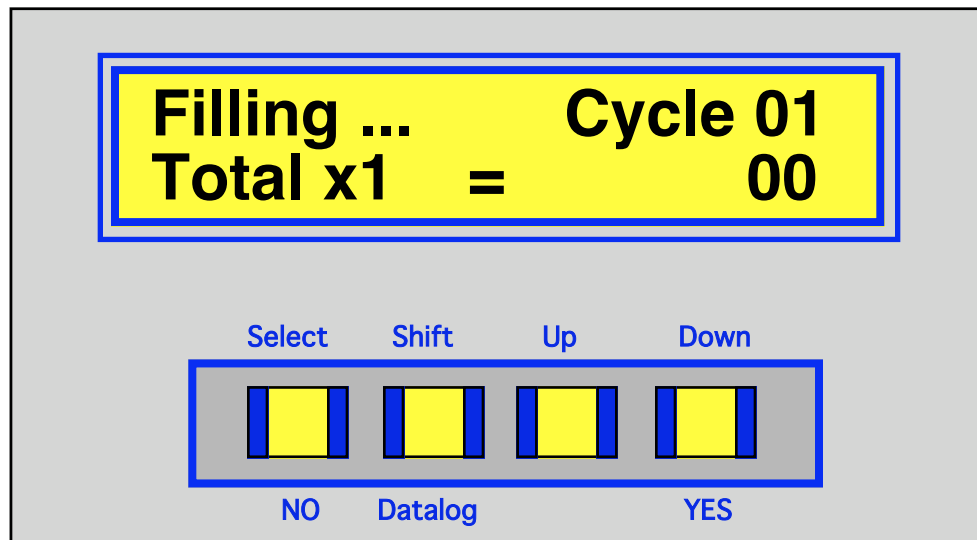

The Monitor is now operating. The 'RUNNING' LED light on the main circuit board should be flashing ( approx. 4 times per second ) and the 'NO SIGNAL' LED should be OFF.

## ***VIEWING THE RUN MODES***

When in the RUN MODE, press the UP or DOWN button to display the RUN MODE parameter you desire. The 4-20 mA. output is not affected by the selection of any RUN MODE window.

The RUN MODE Selections available:

<b>Filling .....</b>	<b>Cycle 08</b>
<b>Total x1</b>	<b>= 12345678</b>

- a] The STATUS of the wet well is indicated along with the CYCLE count for the day.  
STATUS: **Filling** - Wet Well is now filling, level is rising  
**Inflow** - System is monitoring inflow rate  
**HI Inflow** - HI Inflow Rate Warning  
**Pumping** - Pump(s) is running, level decreasing  
**Low Pumping** - Pump rate is below warning setting  
**Low or High Alarm** - Level has exceeded Alarm settings
- b] The TOTAL is an 8 digit totalizer indicating the total gallons pumped to date. The total equals the count displayed times the multiplier i.e. x1, x10, x100 , x1000.

<b>Inflow</b>	<b>=</b>	<b>123.00</b>	<b>GPM</b>
<b>Pumped</b>	<b>=</b>	<b>345.00</b>	<b>GPM</b>

- a] INFLOW equals the inflow GPM rate calculated. This value will update when the LEAD pump turns ON. Inflow rate is calculated by the time it takes to fill the volume between PUMP OFF and LEAD PUMP ON (no Inflow float), or between INFLOW FLOAT ON and LEAD PUMP ON (using Inflow float). Method is user programmable.
- b] PUMPED is the GPM pump rate for this cycle. This value will zero when INFLOW FLOAT starts or when LEAD pump comes ON. The value will update when the pump(s) turns OFF.

<b>GPM</b>	<b>=</b>	<b>345.00</b>
<b>Pump Total</b>	<b>=</b>	<b>657</b>

- a] GPM equals the last cycles pump rate.
- b] PUMP TOTAL is the last pump cycle total gallons pumped.

<b>Start 10:16</b>	<b>Cycle 07</b>
<b>Run Time 00:02:05</b>	

- a] START indicates the time the CYCLE count shown began.
- b] RUN TIME indicates how long the pump ran (or has been running).

Flow % = 34.50  
Days Total = 31246

- a] FLOW % indicates the percent GPM rate on the 4-20mA output#1 only. GPM, LEVEL or INFLO rate will be found on output#2. Output#2 type is user programmable.
- b] DAYS TOTAL is the total gallons pumped so far for the day. No multiplier is used.

LEVEL = 86.53 in.  
Total x1 = 12345678

(only if 4-20mA input is used)

- a] LEVEL indicates the 4-20mA. input value in inches. LEVEL is only available if INPUT TYPE is set for 4-20mA. input. The 4mA and 20 mA values are programmable to scale the input.
- b] The TOTAL is an 8 digit totalizer indicating the total gallons pumped to date. The total equals the count showing times the multiplier i.e. x1, x10, x100 or x1000.

**Note: Press and hold the SHIFT button for 5 seconds will allow for manual operation of pumps.**

## ***PROGRAMMING THE MONITOR***

You may now begin programming the PSM-660 once the STARTUP procedure above has been completed successfully. The keypad on the front panel is used for selecting the various RUN MODE indications and PROGRAMMING MODES of the Monitor. Use the SELECT button to scroll through the program selections, selecting NO/YES where needed. To change any value, use the SHIFT button (moves cursor under the digit to change), UP and DOWN buttons ( to change the value of the selected digit).

The programming of the Monitor is accomplished by first pressing the SELECT button. You will be asked if you want to **GO TO PROGRAM MODE?** If you select YES you will be asked to **ENTER YOUR PASS CODE.** Enter the PASS CODE using the SHIFT , UP and DOWN buttons . If the wrong PASS CODE is entered, the display will return to the RUN MODE last selected.

**Note: The PSM-660 leaves the factory with pass code 0000.**

Press the SELECT button again. You are now asked **CHANGE PASS CODE?** If you like, you may change the pass code at this time by using the SHIFT, UP and DOWN buttons. If you change the pass code .....

### ***Remember your new PASS CODE !!!***

*If you forget your pass code and can not enter into the programming section, you will need to call the factory at 610-942-3190. Please have your units serial number available. It is found on the upper left corner of the main circuit board.*

Press the SELECT button and you will be asked **SELECT INPUT TYPE...** Select YES to enter. Use the UP/DOWN buttons to select the INPUT TYPE you are using. Continue through the programming responding to the prompts. Refer to the **PROGRAM FLOWCHART** in this manual for navigating through all the programming functions.

## **SETTING/TESTING ... 4-20mA OUTPUTS**

There are two (2) 4-20 mA. outputs on the PSM-660 Pump Monitor that can be set and tested using the **TEST 4-20mA OUTPUT?** function under the **MISC Setting....** mode. Enter the TEST 4-20mA OUTPUT by selecting 'YES'. The 4-20mA output should go to 4 mA. or 0%. The display will read ...

<b>4-20mA Output = 00%.</b>
<b>Done +25 +10 -10</b>

*(Note: the 4-20mA output is damped by the **4-20mA Damping** adjustment on the main circuit board. You may want to turn this adjustment fully CCW for quick response of output while testing).*

- 1] Adjust the '4 mA.' potentiometer adjustment of output #1 and #2 (see figure 3, page 8) for 4 mA. output.  
*(Note: perform the 4 mA. adjustment first to eliminate any interaction between the 4 and 20 mA. adjustments).*
- 2] Press the SHIFT button 4 times to simulate 100% or 20mA.  
*(Note: Pressing the SHIFT button adds 25% to the output; the UP button adds 10% and the DOWN button minus 10%. By using the SHIFT, UP and DOWN buttons, you can increment and decrement the output in 5% increments).*
- 3] Adjust the '20 mA.' potentiometer of each output for 20 mA. output.
- 4] Repeat steps above using the Keypad to simulate an output and confirm the 4-20 mA output.
- 5] When completed, adjust the **4-20mA DAMPING** output on main circuit board to desired 4-20mA response.
- 6] Press SELECT (Done) when completed to exit simulate of 4-20mA output.
- 7] Scale each 4-20 mA. output under **FLOW PARAMETERS .... SCALE OUTPUT #1 .... SCALE OUTPUT #2**. Note: Output #2 may be set for GPM, LEVEL in inches or INFLOW Rate in GPM

*Note: if the 4-20mA output is not responding correctly, the output is most likely defective and will require repair or the loop resistance is too high. Do not adjust the 4 and 20mA adjustments to correct for large discrepancies (more than 3 mA.).*

Each of the 4-20mA outputs will drive a 1000 ohm loop resistance.

## **RELAY OUTPUTS**

The PSM-660 has three (5) independently programmed control relay outputs. The programming of relay 1, 2, 3 and 4 is performed when the INPUT TYPE is 4-20mA. input. The user will be asked at what elevation in inches do you want the LEAD pump (relay 1) to turn ON and turn OFF. The same will be asked of LAG 1 (relay 2), LAG 2 (relay 3) and LAG 3 (relay 4). Relay 5 may be used as a LOW or HIGH alarm.

When INPUT TYPE is floats/contact closures, relay 4 will be used for LOW alarm and relay 5 for HIGH alarm. The input floats will control the relays directly. No elevation programming (except for LEAD ON/OFF and INFLO) is needed for the relays. The relay contacts are dry contact closures rated 5 amp, 220VAC. An associated LED will light when the relay is energized.

*Note: when an alarm sounds, pressing any button on the front panel will silence the alarm i.e. turn alarm relay OFF.*

*Note: while in the program mode, the relay outputs will not be affected by any program change. Once you are back in the RUN MODE, the new values will take affect.*

## **TESTING THE RELAY OUTPUTS**

The relay outputs can be tested by going to **MISC Settings ? mode, TEST RELAY OUTPUTS?** Select 'YES'. The display will show ....

Test Relay #0
Done ON OFF Select

- 1] Use the DOWN button to Select the relay number (1 thru 5).
- 2] Press the SHIFT button to turn the selected relay 'ON'.
- 3] Press the UP button to turn the selected relay 'OFF'.
- 4] Press the SELECT button when 'DONE'.

The associated LED light will light when relay is energized.

*Note: when in the RUN MODE, pressing and holding the 'SHIFT' button for 5 seconds will bring you to the TEST RELAY OUTPUTS . This can be useful for quick MANUAL CONTROL of the pumps.*

## **SETTING SEQUENCE / ALTERNATION**

The PSM-660 system may be programmed to ALTERNATE the LEAD and LAG 1 pumps. In the program section select YES when asked **SET PARAMETERS?** See Flowchart #2. Press the select button until you come to **Number of Pumps...** Enter the number of pumps you are controlling. Press SELECT. Enter the Pump Sequence

Order. In this case the sequence order will be 1 2 x x for 2 pumps or 1 2 3 x for 3 pumps (note: 'x' means no pump or control out). Use the SHIFT, UP and DOWN buttons to change values. NO ALTERNATION uses the sequence as entered. ALTERNATE will alternate the first 2 pumps (relays) in the sequence.

The user may also like to ROTATE all pumps (up to 3 pumps with floats; 4 pumps with 4-20 mA input) instead of just alternating the LEAD/LAG. Here is an example on how to program the system to Rotate/Alternate all pumps.

1] Set the number of pumps to 3

Number of Pumps .... 3
---------------------------

2] Set the Pump Sequence to

Pump Sequence Order 1 2 1 3
--------------------------------

3] Set Alternate Type to Rotate

Alternate Type .... Rotate
-------------------------------

The pump sequence will first turn pump 1 on, next is pump 2, then pump 1 again, then pump 3 etc. Other sequence orders can be set: number of pumps 2; sequence pumps 1 2 2 1 etc.

*Note: Setting the SEQUENCE and ALTERNATION type is only necessary when controlling the pumps with the PSM-660 unit.*

## ***SETTING THE TIME AND DATE***

Under the **MISC Settings** ? Set the Time and Date using the SHIFT, UP and DOWN buttons. The Data Logging and 24 hour Summary uses the time/date for logging purposes. The time/date is generally set when it leaves the factory but should be checked.

## ***RESET THE PUMP RUN TIME/EVENT LIST***

Under the **MISC Settings?** you can RESET the pump run time meters and clear the EVENT LIST by selecting 'YES' when asked.

## ***RESET THE TOTALIZER AND DATA LOG***

Under the **MISC Settings?** you can RESET the Totalizer to zero and/or RESET (clear) the Data Log by selecting 'YES' when asked. It is best to do the RESETs when starting up the monitor for the first time or when the Time/Date have been changed.

Note: The EVENT LIST is not Reset by the Data Log RESET.

# DATA LOGGING

The PSM-660 Monitor continuously logs data as measurements are being made. Once data log memory is filled, old data will be written over by new data (auto wrap around). The Monitor has three (3) independent data log types. They are 1] a 24 hour summary; 2] discrete pump cycle summary and 3] an Event list. All data log may be downloaded to a PC/Lap Top for viewing using the RS-232 output (see using the RS-232 output). The 24 hour summary may be directly printed to a serial printer connected to the RS-232 output either on demand or set for AUTO print at end of 24 hour period. The pumped totals in gallons for the past 6 months may be viewed at the Monitor.

## 24 Hour Summary

The 24 HOUR SUMMARY data log keeps track of the daily number of pump cycles, the total RUN TIME for pumping, the Average GPM pump rate and the days pump totals for the past 6 months. The START time for the 24 hour summary may be set by the operator under the **Set Communications** section in the programming. The default setting is 12:00 midnight. The START time begins a new summary page with date and times. To view the 24 Hour Summary you must download the data to a PC/Lap Top computer using the RS-232 output. You will be able to select up to 6+ months of data, preformatted for quick viewing and print out. (see using the RS-232 output for download instructions).

## Viewing Daily Pump Totals at Monitor

The daily totals can be found in the 24 Hour Summary described above or viewed at the Monitor by pressing the SHIFT (DataLog) button while in the Run Mode. You will be asked to View Totals? Press YES. The Date and Total gallons for that date will be displayed. (Note: the Monitor will always begin with todays date. Todays date will show total gallons so far for the day.) Press the UP or DOWN button to select next or previous date; the SHIFT button to go back 1 week at a time or SELECT when finished.

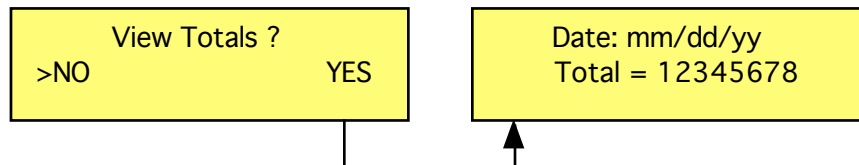

## View Pump Run Time Hour Meters

If NO is selected in **VIEW TOTALS?**, you will be asked to **View The Pump Hours**. Select YES to view pump 1~3 (1~4 if 4-20 mA. input) total pump run time in tenth of hours. Max hours displayed is '9999.9' hours. Press SELECT to return to RUN mode.

## Print Daily Readings

If NO is selected in **VIEW PUMP HOURS**, you will then be asked **Print Daily Readings?** If NO, you will return to the Run Mode. If YES, you can select ...

**Print NOW.** You then will be asked number of days (up to 200). Press Select to begin printing to your serial printer. (Note: the Monitor sends one data

line to the printer and waits approximately 2 seconds for the printer to print before sending the next line. Printing a large number of days may take some time. Approximately 15 seconds per days data).

- **OR** -

**Print AUTO.** The Monitor will display the time the 24 Hour Summary will print each day. (Note: this time is set under Set Communications. Make sure your printer is turned ON). Press SELECT to exit.

### **Detailed Summary**

The Monitor logs each pump cycles data. The detailed data log will indicate the days date, the pump CYCLE NUMBER, which pump came ON, the START TIME of the cycle, the pumps RUN TIME, the measured INFLOW GPM rate, the average GPM PUMP RATE and the total pumped for the cycle. This data can be downloaded to a PC/Lap Top using the RS-232 output.

### **Event List**

The Event List logs the date, time and event type when it happens. Events types are ...

- |                           |                          |
|---------------------------|--------------------------|
| 1] Power Applied          | 10] High Alarm ON        |
| 2] Entered Programming    | 11] High Alarm OFF       |
| 3] 4-20mA Signal Lost     | 12] Low Pumping          |
| 4] 4-20mA Signal Returned | 13] Reset Hour Meters    |
| 5] High Inflow Rate       | 14] Reset Totalizer      |
| 6] Inflow Rate Error      | 15] Reset Data Log       |
| 7] False Cycle            | 16] Reset Event List     |
| 8] Low Alarm ON           | 17] Master Reset/Startup |
| 9] Low Alarm OFF          |                          |

The Events may be viewed by downloading to a PC/Lap Top using the RS-232 output.

### **Resetting The Data Log**

The Data Log may be RESET (clear all data) by selecting YES when asked **Reset The Data Log?** under **Misc Settings**. Note: this does not RESET the Event List. This can be Reset by doing a MASTER RESET to the meter or resetting the PUMP RUN TIMES (hour meters).

## Resetting The Monitor

---

If the SELECT or SHIFT button is held when power is applied to the Monitor, then released, the user will have access to the reset functions.

If SELECT is used, the user may reset the Monitor by saying 'YES' to FACTORY DEFAULTS and 'NO' to USER PRESETS when prompted. The operator must now proceed to reprogramming the Monitor.

Note: This reset will set the pass code to '0000'.

If the SHIFT button is used, MASTER RESET, it will do the same as above plus reinitialize the time/date and reset the Event List. It will be necessary to set the clock and date. Do this RESET if using the SELECT button above does not work. The Resets can help recover from a processor crash or lockup due to lightning etc. The resets do not affect the totalizer or data log. The user may proceed to resetting the totalizer and /or data log in the PROGRAMMING section and setting the time/date if needed.

### If The Monitor Should Lockup or Crash

It is possible that the flow of the program may be interrupted by some external event such as lightning, testing back-up generators or some other anomaly on the AC or inputs that may cause the Monitor to crash or lockup. Turning power OFF and waiting approximately 10 seconds before turning the power back ON may correct/unlock the meter. If not, it may be necessary to perform a RESET using the SELECT or SHIFT button mentioned above, RESETTING THE MONITOR. You should only need to do a FACTORY DEFAULT reset and then reprogram the monitor. You should not need to reset the totalizer or data log.

In extreme cases, it may be necessary to do a HARD Reset by first turning power OFF to the Monitor and then removing the 3 volt clock/memory coin battery from its holder on the circuit board for about 1 minute. This will cause a loss of all data, including totals and data logging.

Reinstall the coin battery (note polarity, see page 12) and do a power up reset using the SHIFT button as mentioned above. Proceed to reprogramming the meter. Set the clock and date and reset the totalizer and data log when asked.

# ***Using The PSM-660 FLOWCHART***

## ***OPERATING INSTRUCTIONS***

When power is first applied, the PSM-660 Pump Station Monitor will run through its POWER-UP windows. It should display 2 windows indicating name of manufacturer, model number, type of meter and the software revision number. The process takes a few seconds and will then enter the RUN MODE. The Monitor will display the window that was ON (selected) prior to turning power 'OFF'. To select or scroll through the RUN MODES, use the UP/DOWN buttons. Each press of the button takes you to the next window. Selecting any of the RUN MODES will not affect the 4-20 mA. output or any of the programmed settings. The Monitor begins monitoring the wet well automatically.

To enter the **PROGRAM MODE**, press the SELECT button. You will be asked **GO TO PROGRAM MODE?**. Press 'YES'. You will be asked for the **PASS CODE** before you can enter into the **PROGRAM MODES**. The pass code is 0000 when it leaves the factory and will remain this until you change it. Press SELECT. If you like to change the code at this time, use the SHIFT, UP and DOWN buttons to enter your new pass code then press SELECT. This stores your new code. You now have access to the program section. If the incorrect pass code is entered, you will be returned to the RUN MODE. **REMEMBER YOUR PASS CODE!!!**

Once you entered the **PROGRAM MODE** you can scroll through it by pressing the SELECT button. The SELECT button performs three functions: 1] NO, 2] ENTER and 3] NEXT WINDOW. Use the SHIFT, UP and DOWN buttons to change the values in each window as needed. The DOWN button is used to select YES when data values are not displayed. The Programming Flowchart will guide you through the many features and functions available to you. A brief explanation for each window is provided in the flowchart.

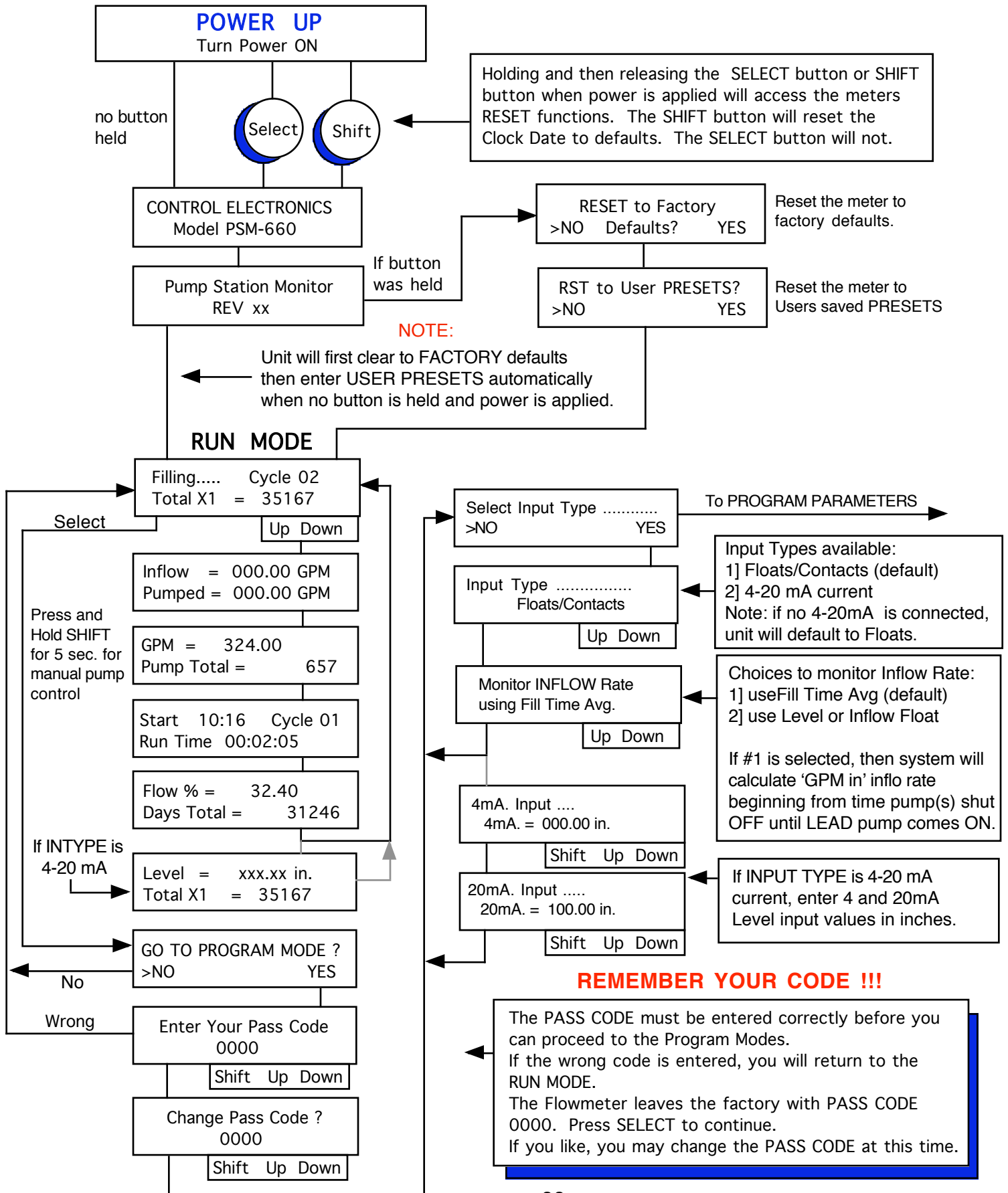

PROGRAM MODE

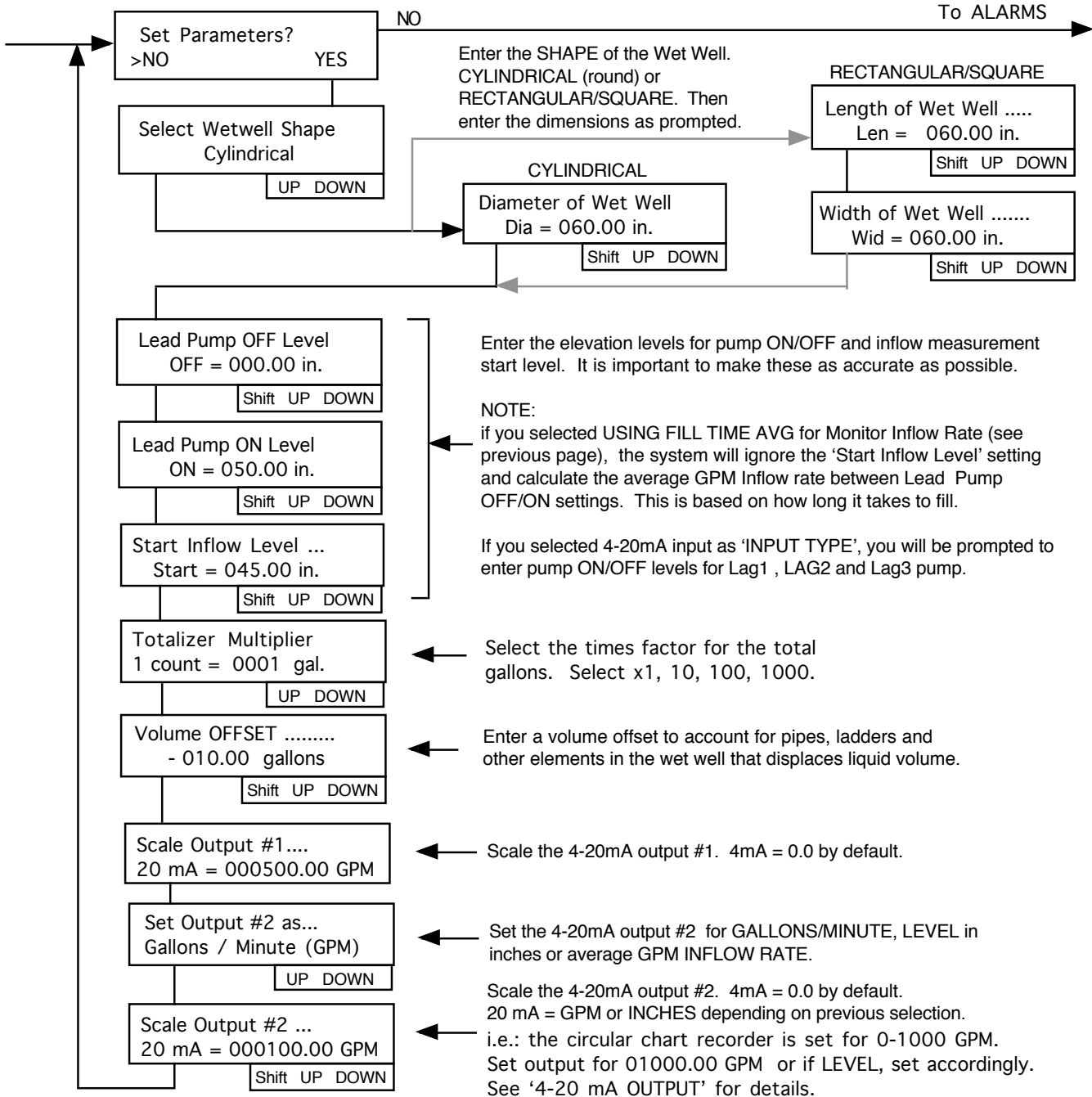

**PUMP CONFIGURE**

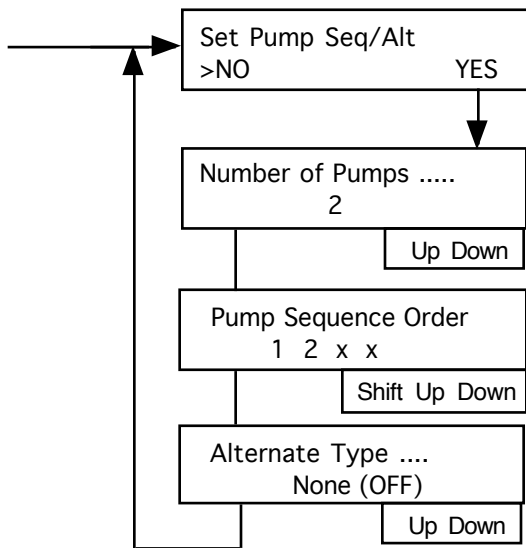

To ALARMS (below)

Enter the number of pumps to control, the sequence order and alternate type. Max number of pumps is 3 with floats (note: high alarm could be used for 4th pump) or 4 with 4-20 mA input. 'x' in the sequence order means not used.

Alternate types are: None (OFF), Lead/Lag or Rotate . Lead/Lag will alternate the first 2 pumps in the sequence order. Rotate will look at the Pump sequence Order and rotate thru them, advancing after each cycle. i.e. sequence order is 1 3 2 x . Next order is 3 2 1 x then 2 1 3 x then 1 3 2 x etc.

Note:

In order for pump 3 and/or 4 to function, you must enter the number of pumps as 3 or 4 etc. and set pump sequence order to show pump.

**If you are not controlling the pumps with the PSM-660 unit (i.e. monitoring flow volume only), set Alternate type to NONE (OFF).**

**ALARMS**

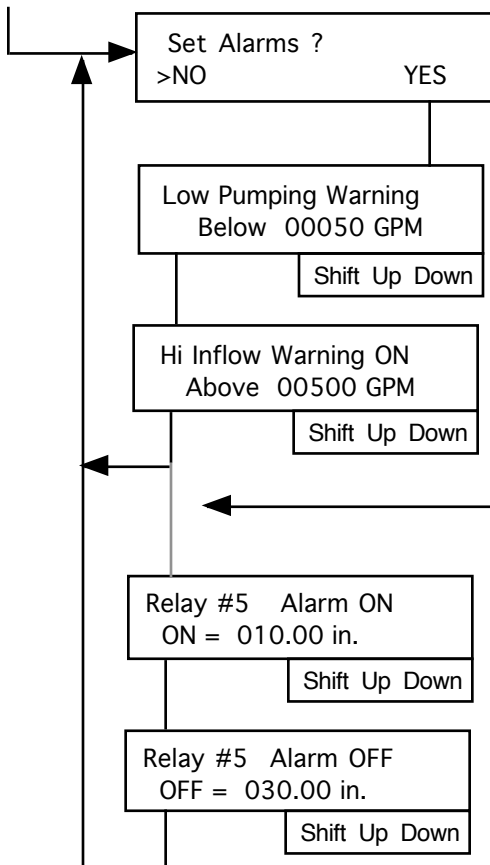

To SET COMMUNICATIONS

Alarm will write LOW PUMPING warning on the display if the calculated GPM pump rate is less than value entered. Event will be logged

Alarm will write Hi INFLOW warning on the display if calculated inflow GPM rate is above the entered value. Event will be logged

If INTYPE selected is 4-20 mA input, you will be asked to enter Relay #5 alarm points.

Alarm will energize if Level exceeds value entered.

Note:

if OFF level is greater than ON level, relay 5 will be a LOW ALARM.

If ON level is greater than OFF level, relay 5 will be a HIGH ALARM

**NOTE:**

If High or Low alarm is sounded, press any button on the front panel to silence the alarm (deenergize relay #4 and/or relay #5).

COMMUNICATIONS / DATA LOG

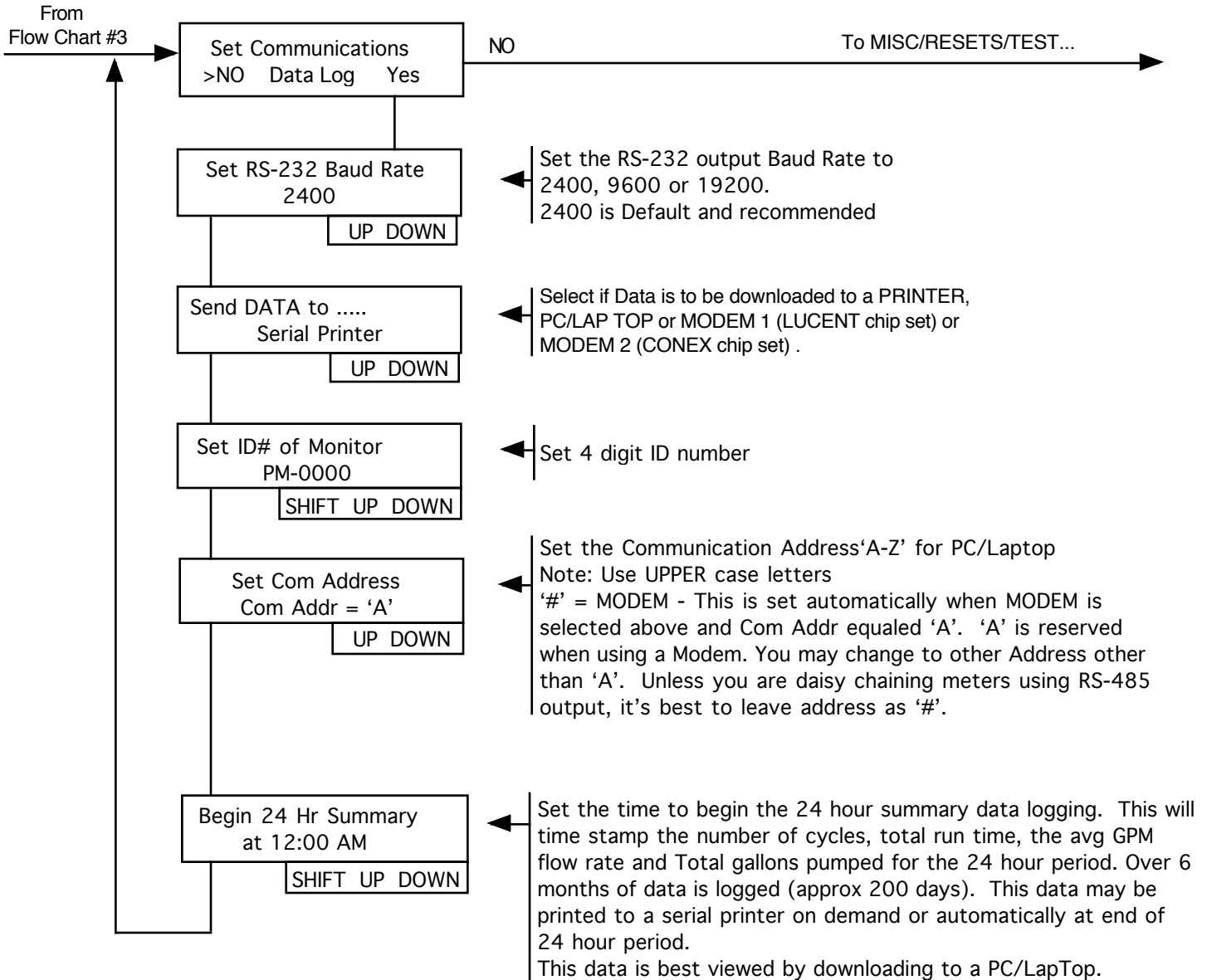

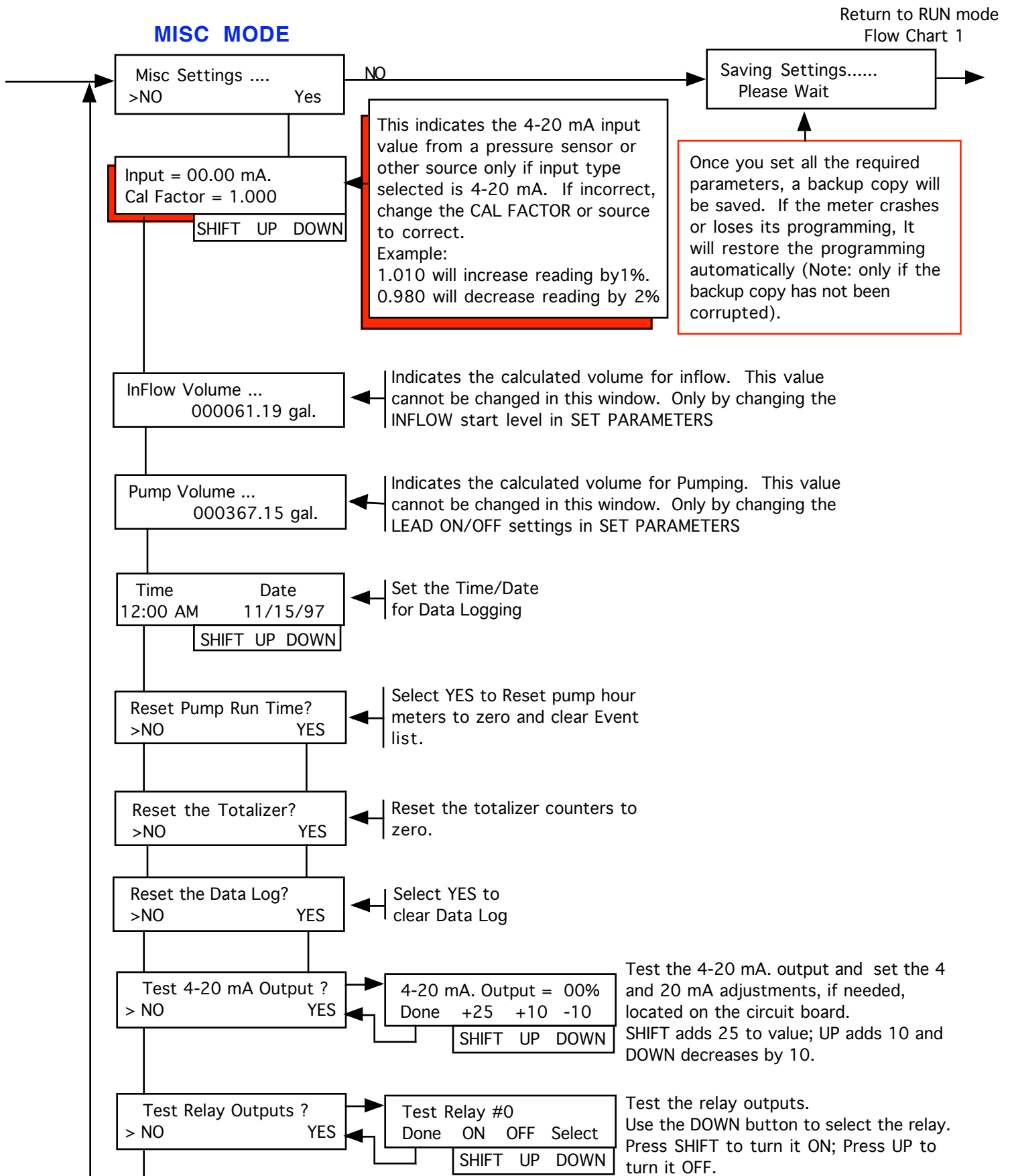

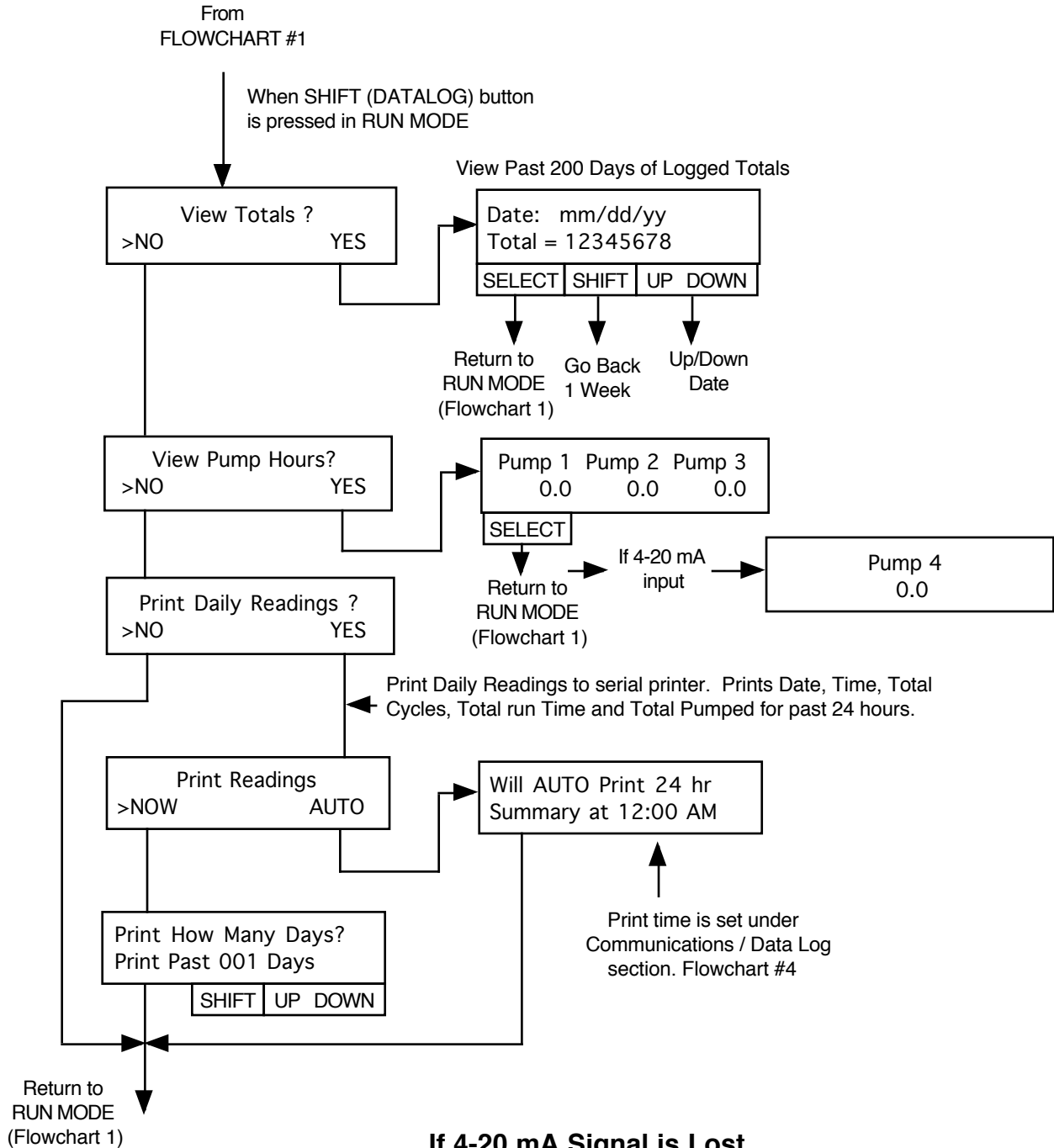

**If 4-20 mA Signal is Lost**

If the PSM-660 system loses the 4-20mA signal, this warning will be displayed and relay 5 will turn ON. If this occurs, check all wire connections / splices for damage or 4-20ma source. Press any key to remove warning and again to turn relay 5 OFF. If 4-20mA returns, the warning will be removed and relay 5 will turn OFF.

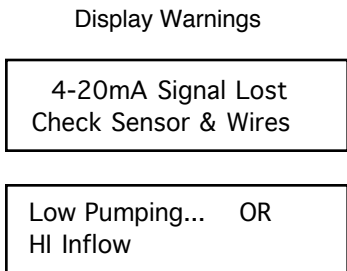

Low Pumping or Hi Inflow displayed are only warnings, no action is taken. Low Pumping may indicate a clogged pump. Hi Inflow may indicate a defective INFLO float.

## Using the RS-232 Communication Output Port

The Operator may choose to communicate with the PSM-660 using their PC/Lap Top computer or Modem to download the logged data for further viewing and analysis or view the present status of the Monitor. This may be accomplished by using any standard communication software package such as Microsofts WINDOWS HYPER-TERMINAL. All data downloaded is in ASCII format. Each line of data is terminated by a CR (carrage return) and line feed. Connect your communication cable to the RS-232 terminal barrier or RJ11 modular jack (located at bottom right corner of circuit board) and your PC communication port (COM 1 or COM 2) as indicated or to Modem (see dwg#100-05).

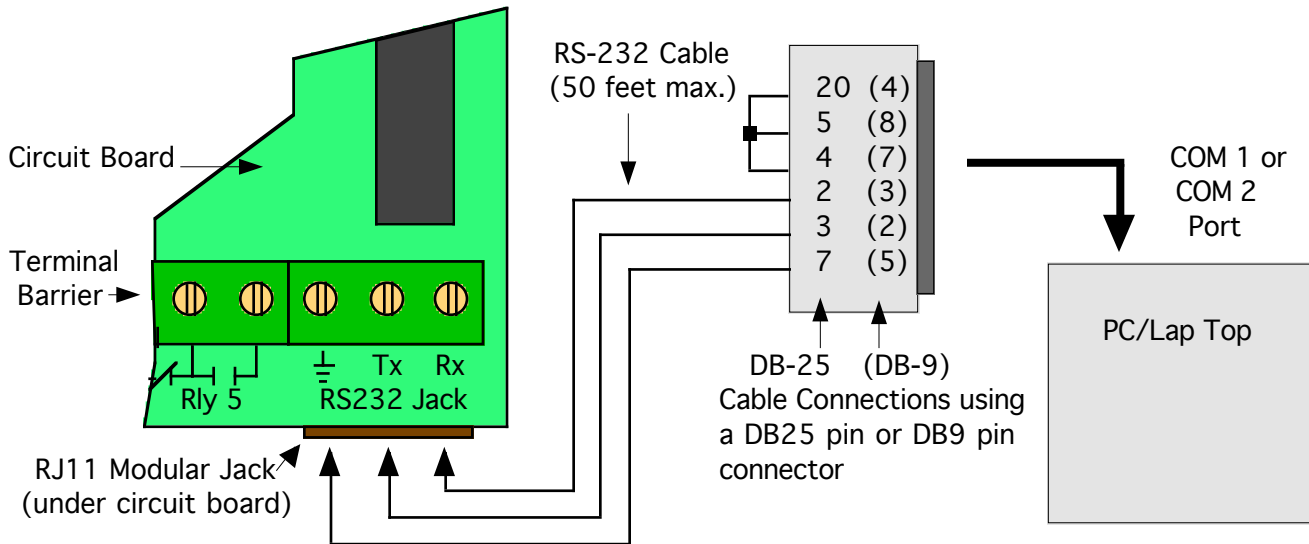

**Make the connections shown to a 25 pin or 9 pin cable connector/socket as shown. An RJ11 modular cable with 9 pin adapter to COM 1 or COM 2 port on PC/Lap Top may also be used. Maximum cable length not to exceed 50 feet. Lengths up to 4000 feet may be accomplished using the optional RS-485 output with our remote receiver.**

In order to successfully download data, you must first match the communication settings in both the PSM-660 and the PC. The Monitor sends data in one of three baud rates - 1200, 2400 (default) or 9600 baud. The baud rate is set in the Monitor by the user under the **Set Communications** program section. You may set the Monitor's ID# at this time, the Com Address (default = 'A', suggest leaving as 'A') and whether data will be sent to a SERIAL PRINTER, PC/Lap Top or MODEM.

### **Saving To File**

If you like to save the data to a file, you must first set your communication software in the PC to 'begin capture' (under HYPER TERMINAL 'TRANSFER' menu. See your PC/software owners manual for assistance). It is not necessary to 'capture' the data if you only want to view it on the PC/Lap top. You may set the 'begin capture' after the initial 'MENU' has been downloaded from the Monitor and before making a MENU selection. When Download is completed, select 'Stop capture' under the 'TRANSFER' menu in HYPER TERMINAL.

### *Communication Settings Using A Modem*

You will first need to open WINDOWS HYPER TERMINAL by selecting: START/PROGRAMS/ACCESSORIES/COMMUNICATIONS/HYPER TERMINAL. Open HYPER TERMINAL and select, if necessary, under FILE/PROPERTIES... 'CONNECT USING' and your PC MODEM. Enter phone number etc. for the Monitor location. (see drawing 100-05 for cable connections).

### *Communication Settings Using A Direct Connection to COM Port*

Same as above (Using A Modem) except under 'CONNECT USING', select 'Direct COM 1 or COM 2', whichever you are connected to with your RS-232 cable. You should set the PC parameters to match the Monitors baud rate, no parity, 8 bit, 1 stop bit, XON/XOFF disabled (no handshaking) i.e. 2400,N,8,1.

**IMPORTANT**

*Do Not use XON/XOFF or other hardware handshaking.*

### *Using A Serial Printer (see flowchart #6)*

Select SERIAL PRINTER under **Set Communications .... Send DATA to....** in Monitor programming. This mode is used to send data to a serial printer and is fairly slow, because a 2 second delay is performed by the Monitor for each line sent to allow the printer time to print the line. Be sure to set the serial printers baud rate to match the Monitor's. See drawing 100-06. Printing of data is initiated from the Monitor by pressing the SHIFT (Data Log) button while in the Run Mode.

### *To Initiate Download from a PC/Laptop or Modem:*

Connect the communication cable to the RS-232 connector on the Monitor to your PC/Lap Top COM port if not using a MODEM. Open your PC communication software (i.e. HYPER TERMINAL), then:

**1] If Direct Connection...**

type SHIFT-'A' (= com addr set by user - 'A' is default) for Monitor's attention.

**If using a MODEM...**

dial up the Monitor first. Once connection is made, type SHIFT-'#' or Com Address programmed other than 'A'. 'A' is reserved when using a MODEM.

**2] Monitor should respond with a greeting, model number and a short menu.**

**Hello!**

**Control Electronics PSM-660 Pump Station Monitor  
Enter Download Selection Type....**

- 1] 24 Hour Daily Summary
- 2] Detailed Summary
- 3] Present Status
- 4] Event List
- 5] Reset Totals
- 6] Reset Data Log
- 7] Reset Event List
- 8] Show Menu
- 9] Terminate Communication

**Hit SPACE Bar to interrupt Download.**

**Your Choice .....**

**>**

Once communication is established, you may select type of download by typing the number of the selection.....

- 1] will download the past 30 to 200 days 24 hour Summary with DATE, TOTAL PUMP CYCLES, TOTAL RUN TIME, AVG GPM and TOTAL PUMPED in gallons.
- 2] will download detailed data of each pump cycle providing DATE, PUMP NUMBER, CYCLE NUMBER, START AND RUN TIME, AVG GPM rate and TOTAL PUMPED for cycle.
- 3] Present status of Monitor.
- 4] Time Stamped list of EVENTS and ALARMS.
- 5] Resets the total gallons count and terminates communication.
- 6] Resets the Data Log and terminates communication.
- 7] Resets the EVENTS LIST and terminates communication.
- 8] Show MENU again.
- 9] Terminates communication with the Monitor. If using a Modem, make sure to terminate modem connection under HYPER TERMINALS 'CALL' menu.

***Please note:***

- 1] while the Monitor is downloading data, the Monitor may stop monitoring the wet well until download is completed.
- 2] Hit 'SPACE' bar at any time to interrupt the download.
- 3] All downloads begin with the most recent data.
- 4] All downloads begin with a header indicating model#, ID# and date.
- 5] Pressing any key on the PSM-660 unit will terminate communication.

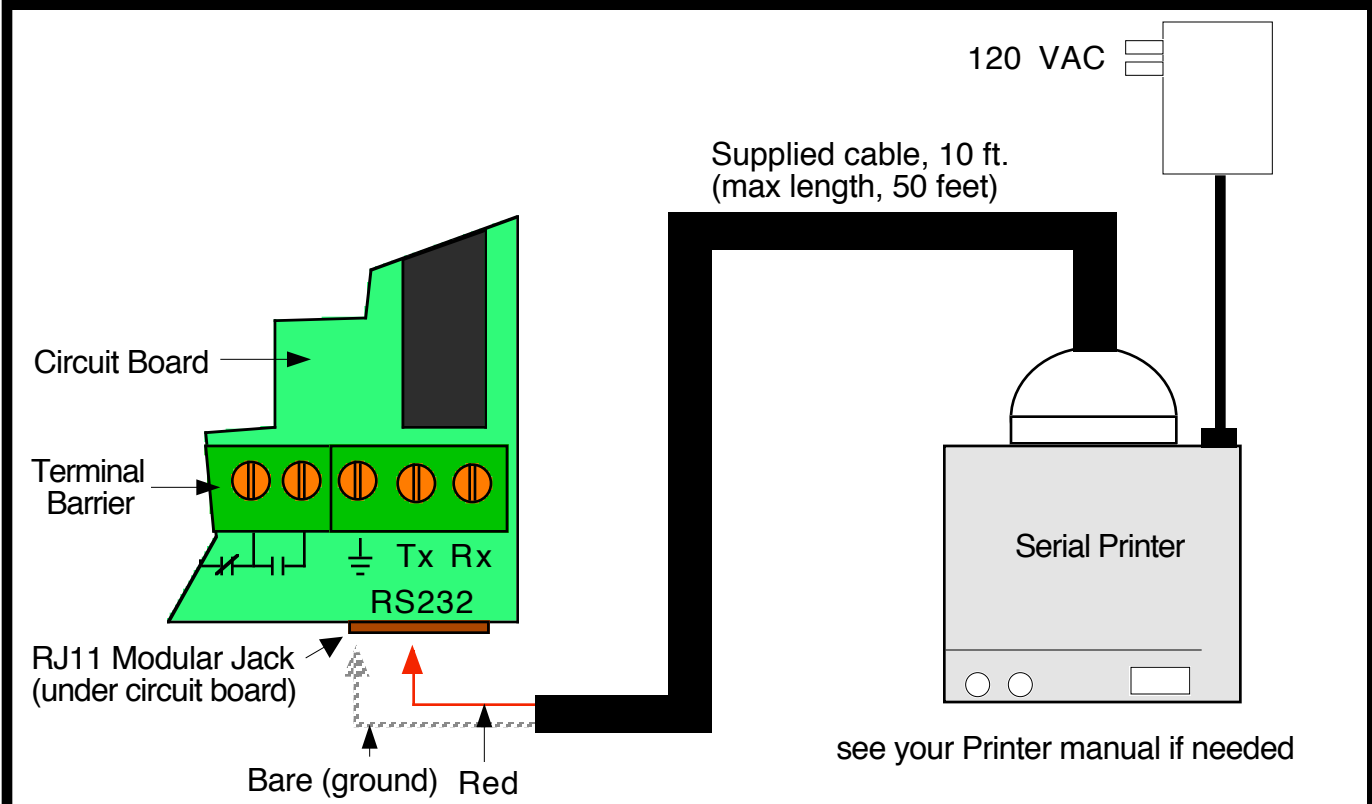

Make connections shown with supplied cable

25 pin Cable Connector to Printer

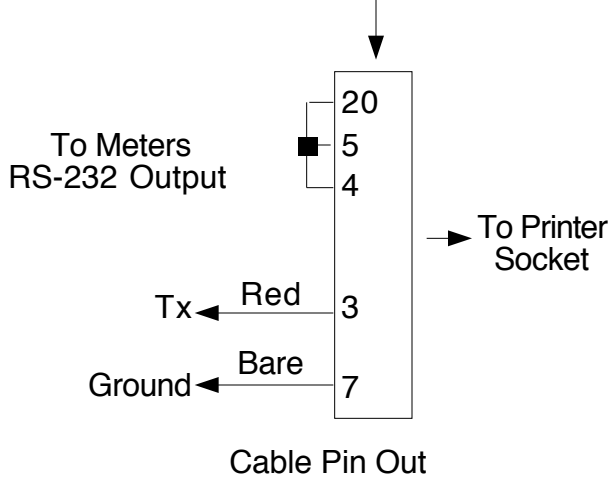

Control Electronics, Inc.	
<b>PRINTER Connection</b>	
Date: 1/1/05	Drawing 100-05

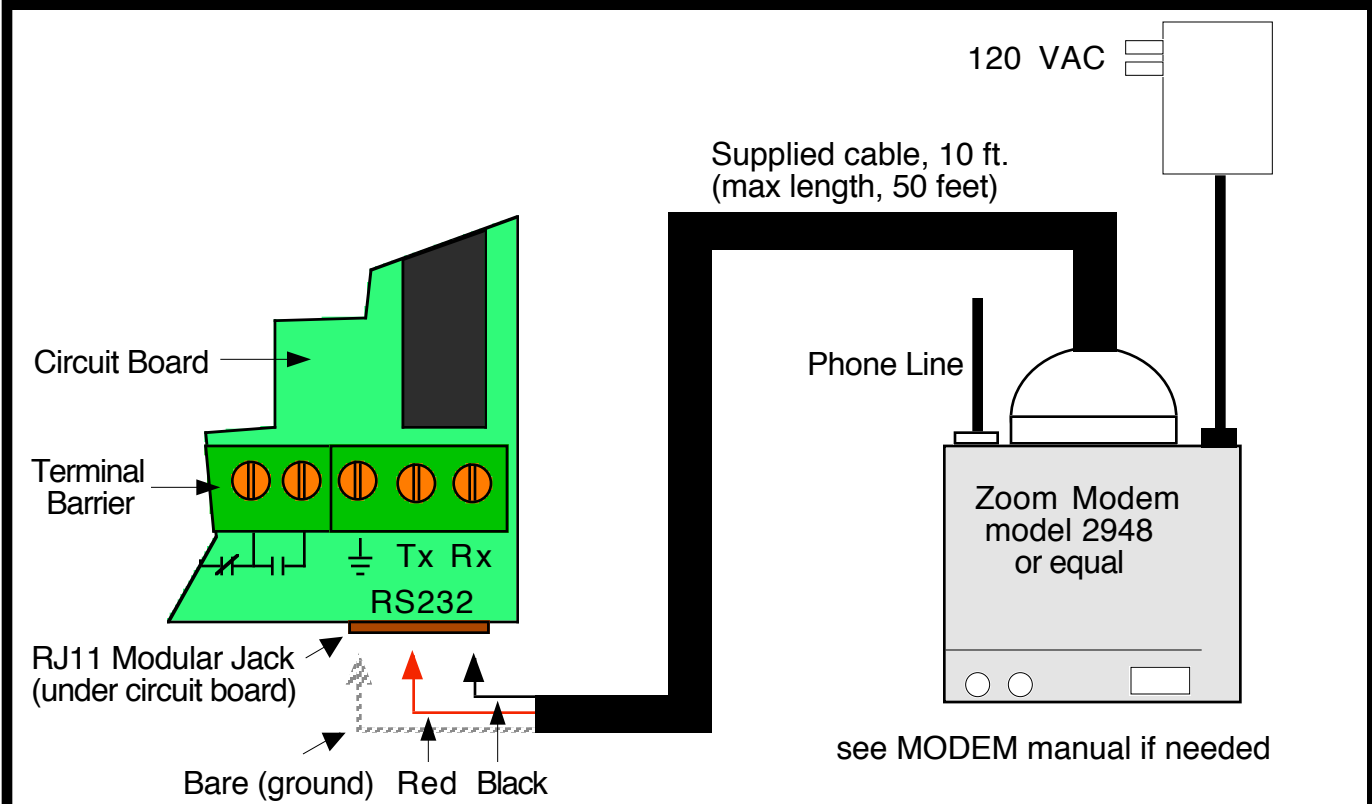

Make connections shown with supplied cable

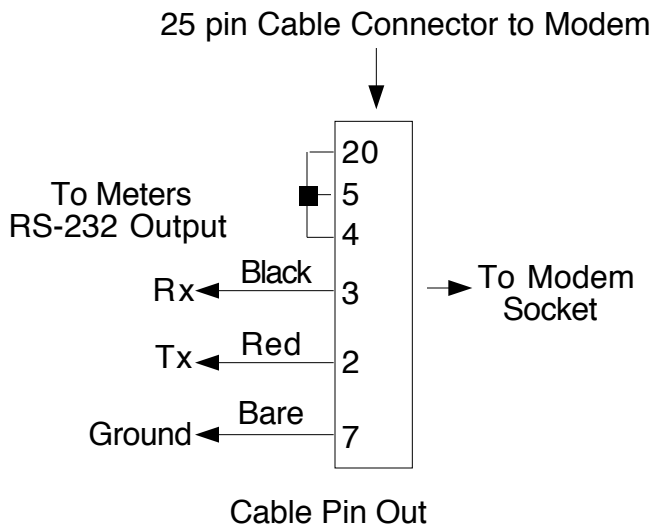

The Meter has been programmed to operate with most modems. Some modems may not function properly.

Connect as shown and turn ON the modem. Select MODEM under DOWNLOAD DATA TO in programming of the meter. See FLOWCHART for assistance.

Use Microsofts HYPER TERMINAL for WINDOWS to dial up modem. Once modem answers and connection is made, the dial-up window will close. Type 'SHIFT-#' or selected COM ADDRESS (other than 'A') to download meters MENU.

See USING THE RS-232 OUTPUT in meters manual.

Control Electronics, Inc.	
<b>MODEM Connection</b>	
Date: 1/1/05	Drawing 100-06

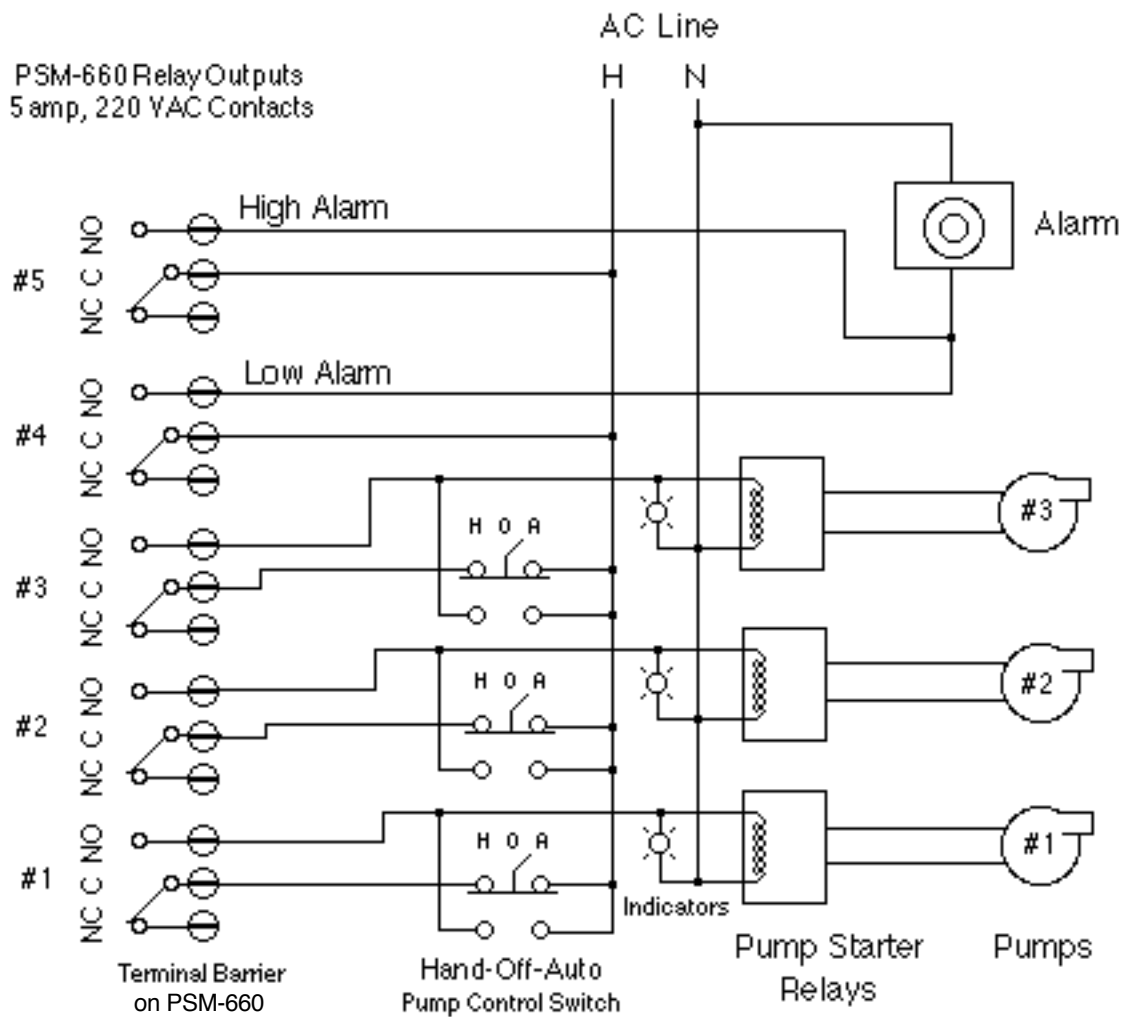

**Typical Wiring to Control Panel  
with HAND-OFF-AUTO switch  
for pumps, pump ON indicators  
and Alarm Annunciator**

Control Electronics, Inc.

## Pump Control Connections

Date: 1/1/05

Drawing 100-07

#1

### 4-20mA Standard Input

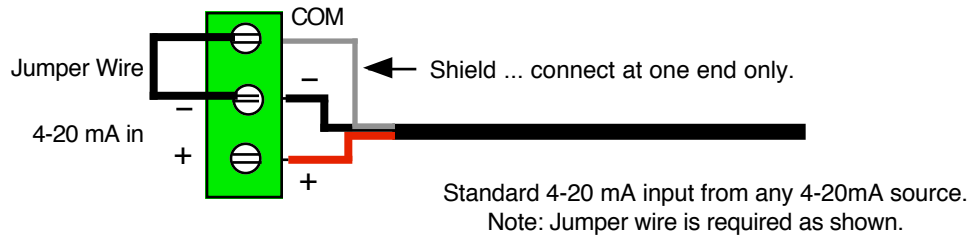

#2

### Loop Power w/ External Power Supply

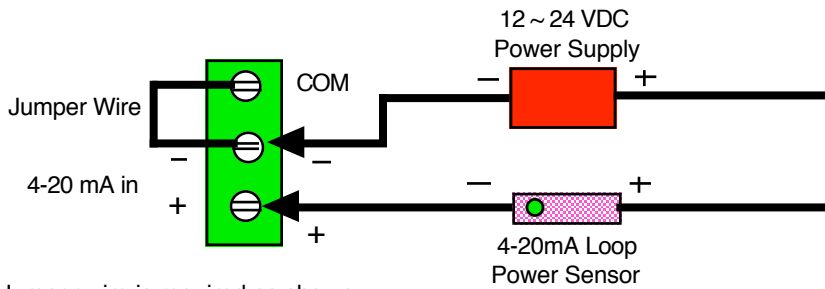

#3

### Loop Power Using Internal Power Supply

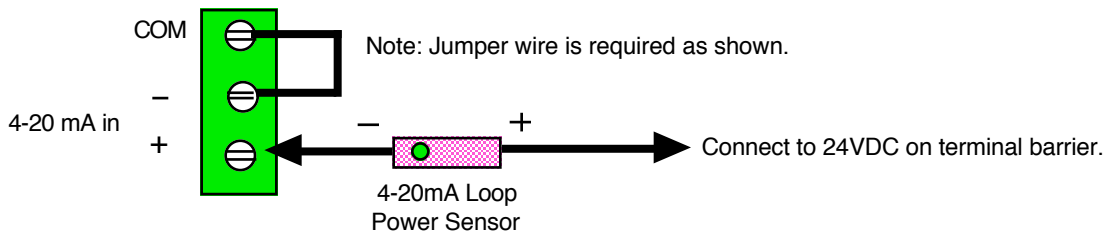

OR

#4

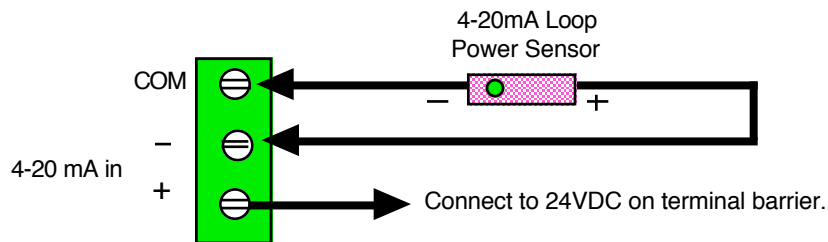

## PSM-660 4-20 mA. Input Configurations