

**PDS-360/360DX
ULTRASONIC
OPEN-CHANNEL
FLOWMETER**

**INSTRUCTION MANUAL
Series 'D'**

CONTROL ELECTRONICS, INC.

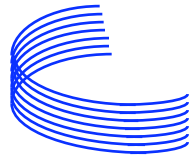

Ship To:



Via UPS

CONTROL ELECTRONICS, INC.

148 Brandamore Rd.
Brandamore, PA 19316

Mail To:

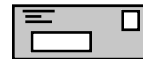

CONTROL ELECTRONICS, INC.

P.O. Box 330
Brandamore, PA 19316

Tel: (610) 942-3190

Fax: (610) 942-3672

<http://www.controlelectronics.com> e-mail: cei@controlelectronics.com

Rv. 2006.2.1

INDEX

SPECIFICATIONS	IV.
REPAIR / RETURN POLICY	V.
PRODUCT PERFORMANCE STATEMENT	VI.
WARRANTY	VII.
... Please read first before installing flow meter.	
INTRODUCTION	1.
INSTALLING THE FLOWMETER	2.
1. CONTROLLER INSTALLATION	
Enclosure Location	2.
Conduit Entrances	3.
Enclosure Mounting	3.
2. SENSOR INSTALLATION	
Sensor Location	4.
a] Parshall Flume	
b] Palmer/Bowlus Flume	
c] V-Notch Weir	
d] Rectangular Weirs	
Using A Stilling Well	5.
Sensor Mounting	6.
3. ELECTRICAL CONNECTIONS	
Sensor Cable	8.
120VAC Input	9.
AC Output / Heater.....	9.
4-20mA. Output	9.
Setpoint Relay Outputs	9.
Sampler Pulse Relay Output	10.
ZERO Meter Input	10.
DC Volt Outputs	10.
Battery Operation	10.
4. ADJUSTMENTS AND CONTROLS	
Transmitter / Receiver Card	
GAIN adjust	11.
THRESHOLD	11.
Xmit / L2 Tuning Coil	12.
BLANKing	12.
PRE-GAIN	12.
XMIT LED	12.
Main Circuit Board	
4-20mA. adjustments	12.
DAMP Adjustment #1 and 2	12.
A/D Ref Adjustment	12.
ON/OFF switch	12.
120/220VAC Select	12.
LED's 1 thru 5	13.
Running LED	13.
No Signal LED	13.
Clk/Mem 3V Battery	13.
STARTING UP THE FLOWMETER	14.
Check List	14.
Turning Power ON	14.

INDEX (CONT'D)

PROGRAMMING THE FLOWMETER	16.
LCD DISPLAY SELECTIONS	
GPM, MGD, DEPTH, TOTALIZER	16.
Flow%, Temperature	17.
LF (Low Flow)	17.
BEGIN PROGRAMMING	
Pass Code	17.
ZERO Flow Distance	18.
Set The Primary Device	18.
Set The SPAN (max flow depth)	18.
Setting the 4-20 mA. Outputs	18.
Testing the 4-20 mA. Outputs	18.
Damping Adjustment	19.
Setting The Sampler Pulse Output	19.
Setting The Relay Outputs 1-4	19.
Testing The Relay Outputs	20.
Setting The Time and Date	20.
Resetting the Totalizer and Data Log	20.
Temperature Probe	20.
CHANGING CALIBRATION REFERENCE	22.
DATA LOGGING	23.
24 Hour Summary	23.
Viewing Data Log	23.
Print Daily Readings	23.
Average Flow Samples	24.
Event List	24.
Resetting The Data Log	24.
RESETTING THE FLOWMETER	25.
If Flowmeter Locks Up or Crashes	25.
USING THE PROGRAM FLOWCHART	
Operating Instructions	26.
Power Up Flowmeter	27.
RUN MODES	27.
Pass Code	27.
Set PRIMARY DEVICE	28.
Setting FLOW PARAMETERS	29.
SETPOINTS (Relay Outputs)	30.
Sampler / External Counter Pulse	30.
Set Communications / Data Log	31.
Set CALIBRATION REFERENCE	32.
Set TIME/DATE	32.
Reset TOTALIZER / DATA LOG	32.
Temp Probe ON/OFF	32.
Test 4-20 mA. / Relays	32.
Viewing the DATA LOGGED	33.
Print / Download DATA LOG	33.
Display Warnings	33.
USING RS-232 COMMUNICATION PORT	
Wiring Connections	34.
Saving Download To File	34.

INDEX (CONT'D)

Settings For MODEM	35.
Settings For Direct To PC COM Port 1 or 2	35.
Using A Serial Printer	35.
Initiate DOWNLOAD from a PC or MODEM	35.

ILLUSTRATIONS

Flume - Weir Types	4 & 5.
Stilling Well	5.
External Battery Connection	10.
3 Volt Battery Installation	13.
RS-232 Output Connections	34.
FIGURE 1. Enclosure Mounting / Dimensions	3.
FIGURE 2. Sensor Mounting	6.
FIGURE 3. PDS-360 Wiring Diagram	8.
FIGURE 4. Ultrasonic Xmit / Receive Card	11.

Back of Manual

RS-232 Serial Printer Connection, Drawing 100-02
RS-232 Modem Connection, Drawing 100-03
PVC Sensor Mounting Bracket, Drawing 100-04
Troubleshooting Guide



Electronics

Power Requirements: 120/220 VAC, $\pm 15\%$, 50/60 Hz
12-24 VDC @ 15W max.

Temperature: 30°F to 120°F (-5°F with opt. heater)

Display: 2 line x 20 character, Alphanumeric, LCD with LED backlighting

Totalizer: 8 digit accumulative with programmable multiplier; x1, x10, x100, x1000
200 daily, 8 digit totalizers

Outputs: Two (2) independent 4-20 mA isolated into 1000 ohm, RS-232 terminal and RJ11 modular jack (USB port opt.), 5 relays - 4 control and 1 programmable (sampler) pulse, SPDT 5A/250 VAC contacts

Span Range: 0-1.00" to 0-150.00" full scale

Dead Band (blinking): 10.0" to 36.0"

Display Resolution: 0.01", 0.01 gal/min

Accuracy*: $\pm 0.5\%$ of range, calculated error less than $\pm 0.04\%$

Memory: Flash and non-volatile RAM

Flow Equations: Parshall, Palmer-Bowlus, Leopold-Lagco, Rectangular Weirs with or without end contractions, V-Notch Weirs, User Defined, Programmable Lookup Table

Data Log: 200 day 24 hour flow summary: min, max, avg GPM, total gallons - time stamped
Avg. GPM flow rate with programmable log rate of 00-99 minutes in 1 minute increments - time stamped; EVENT List

* Note: field conditions, such as turbulence, poor installation etc., may affect the apparent accuracy.

Note: 360DX system has no relays or data logging.

Sensor w/temp probe (US70TC)

Material: PVC Housing, Epoxy

Beam / Freq. 5° Conical, 40 kHz pulsed

Temperature: -40°F to 160°F

Cable: 30 foot corrosion resistant, 1500 ft. max, Belden# 8451

Dimensions: 3.0" dia. x 4.0" Len

Mounting: 3/4" male

Sensor is considered explosion proof, corrosion resistant, immersible, suitable for Class 1, Div. 1, Grps. C, D.. Class II, Div. 1, Grps. E,F,G

Enclosure

Material: Fiberglass with clear hinged Polycarbonate cover

Rating: NEMA 4X, IP65, Dust-Tight, Water-Tight, Corrosion Resistant, CSA, UL listed

Dimensions: 7.2"x11.8"x6.8"

Mounting: 4.92"x12.3" with stainless steel mounting feet

Options

Heater/Thermostat, PVC Sensor Bracket, Sensor Cable, USB Port, Modem

Warranty: the PDS-360 system is pretested and inspected before shipping. Warranty is against defects in parts and workmanship for a period of one (1) year from ship date.

Specifications and design subject to change without notice.
Made in USA.

DIMENSIONS

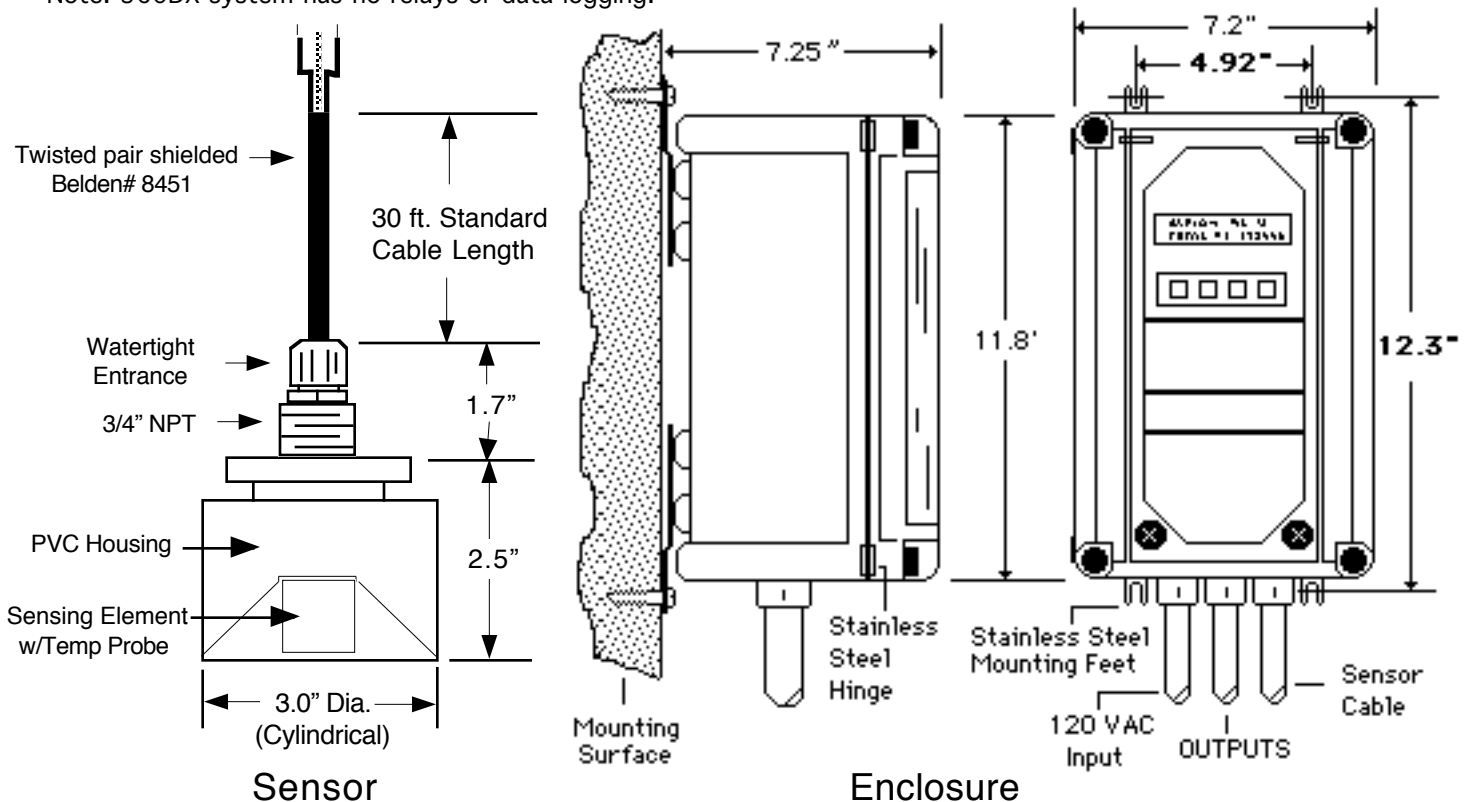

Repair Policy: All repairs are performed on our premises. Repairs must be sent to Control Electronics by UPS prepaid. **NO ARM** number is required. However ...

Customer must enclose:

- 1] a description of problem
- 2] who to contact
- 3] phone number
- 4] return ship-to address
- 5] **method of payment**, Credit Card or COD.
A Company Purchase Order Number must be supplied if other payment method is to be arranged.
- 6] **Unit / Sensor must be cleaned** before shipping to Control Electronics. We reserve the right to refuse repair or to apply a \$ 50.00 charge to repair of a product that has not been received cleaned.
Cleaned unit means removing any debris that may be clinging to the unit; wiping off loose dirt, cob webs, dead insects etc.

Delay of repair may occur if any of the above is not provided. Most repairs are processed and shipped within 48 hours of receiving repair unless a major repair is required.

Repair Cost: A minimal charge will be applied regardless of repair needed plus return shipping charges. If repair exceeds quoted minimal charge (call factory for quote), we will notify the customer before we proceed.

Payment is COD or Credit Card only unless other arrangements are made.

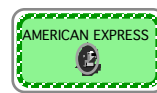

Warranty Repairs: Warranty repairs are made at our discretion and returned UPS GROUND at our expense.

Return Policy: Control Electronics will accept 'return of product' for credit within 6 months of shipping date if it is determined that the product is not performing to specification as described in Product Performance statement in this manual (provided application is not the cause of problem). We do not accept returns for credit when the application is the source of the problem (i.e. poorly installed flumes, poor piping arrangements, **interference from other equipment** etc.), product is misapplied or not used properly and/or if product is out of warranty.

A **35% restocking charge** will be applied if product is returned for credit after 6 months from ship date.

Control Electronics does not accept returns of options such as circular recorders and other products not manufactured by Control electronics, Inc.

Control Electronics will not accept returns of used Sensors, cables, or spare parts unless shown to be defective under warranty or not performing as specified.

Any credit issued will be at the discretion of Control Electronics, Inc. Warranty of product is limited only to the repair or replacement (with same model) of defective product.

Any product or part of product returned damaged will not be considered for any credit.

Customer must call for authorization before returning product for credit. Products returned for credit will not be considered without prior authorization.

A description of how it was determined that the product was not performing to specification must accompany the return of the product for our evaluation before Control Electronics will consider any credit. The name of who to contact along with phone number should also be included with the return.

Packing: Repair / returned units must be packed in a suitable cardboard box with sufficient packing material (newspaper, packing peanuts etc.). Control Electronics is not responsible for any product damaged through shipping. Make sure you insure the package for replacement cost. **DO NOT pack the unit upside down or sideways in the box.** Damage could result to product if you do.

Ship To Address: All repairs or returns must be shipped prepaid via UPS or equal to:
Control Electronics, Inc., 148 Brandamore Rd., Brandamore, PA 19316

CONTROL ELECTRONICS, INC.

PDS-360 Product Performance

Control Electronics PDS-360 Flowmeter will perform as specified when tested under known, simulated conditions. All PDS-360's are tested for full functionality and performance before shipping.

The **accuracy** of the product is determined by inputting a known, stable target distance into the system and monitoring its ability to process the return ECHO delay accurately and conversion of the calculated DEPTH indication to GPM and Total flow as related to the built-in equations. Specifications for the product are determined by this method.

The **accuracy** of the product is not determined by any other method. Other tests methods indicate the accuracy of the over-all application/installation, not just that of the product. Such tests are not acceptable as an indication of product(s) accuracy. However, other test methods can be used to determine if the calibration of the product should be changed in attempt to compensate for application/installation conditions. This should only be done if no other application/installation corrections can be initiated to correct the problem.

Some examples of application/installation problems are:

- 1] Flume/Weir not sized properly
- 2] Strong vapours from liquid or severe air density changes
- 3] too much turbulence or foaming on the liquid surface
- 4] Flow moving too fast through the flume/Weir
- 5] Flow approach to flume/weir incorrect
- 6] Sensor not installed properly etc.

Some equipment such as variable speed drives, nearby radio transmitters (i.e.: radio dispatch or hand held transmitters) etc. located next to the product or even at times in adjacent rooms may possibly interfere with the products performance. The worst of these is the variable speed drive controllers. This type of equipment generates large amounts of electrical and RF (radio frequency) noise that can interfere with the products ability to interpret the return ECHO signal. Some adjustment to the product , relocation of the product or different electrical grounding attempts may minimize or eliminate the interference. Ultimately, it is up to the user to make the corrections necessary and require that the source that is causing the interference be corrected.

If you have any questions in regards to product performance, please contact Control Electronics at (610) 942-3190 or fax us with application conditions and questions at (610) 942-3672. You may also E-mail us at: cei@controlelectronics.com.

CONTROL ELECTRONICS, INC.

PRODUCT WARRANTY

WARRANTY:

Control Electronics, Inc. warrants to the buyer that its products are free from defects in materials and workmanship at the time of shipment and during the WARRANTY PERIOD. Control Electronics, Inc. obligation under this warranty is limited to the replacement of the product(s) by same product(s) manufactured by Control Electronics, Inc. or repair of the product(s) at the Control Electronics, Inc. facility. Control Electronics, Inc. products are sold with the understanding that the buyer has determined the applicability of the product(s) to its intended use. It is the responsibility of the buyer to verify acceptability of performance to the actual conditions of use. Performance may vary depending upon these actual conditions.

This Warranty is in lieu of any other warranty, expressed or implied. This includes, but is not limited to, any implied warranty of fitness for a particular purpose, or other obligations or liabilities on the part of Control Electronics, Inc. Under no circumstances will Control Electronics, Inc. be liable for any loss, damage, expense, or consequential damages of any kind arising in connection with the use, or inability for use, of Control Electronics, Inc. products.

WARRANTY PERIOD:

This warranty is in effect for twelve (12) months from the date of shipment from Control Electronics, Inc. place of business. Any extension of warranty period must be requested at time of purchase and made part of purchase order.

LIMITATIONS:

Control Electronics, Inc. products must be installed and maintained in accordance with Control Electronics, Inc. published instructions. Users are responsible for the suitability of the product(s) to their application. There is no warranty against damage resulting from corrosion, misapplication, improper specification, improper installation or any conditions beyond the control of Control Electronics, Inc. Claims against carriers for damage in transit must be filed by the buyer. Control Electronics, Inc. is not liable for labor costs incurred in removal, reinstallation, or unauthorized repair of its product(s). Control Electronics, Inc. warranty does not cover travel time or expenses for job site service. Requests for field service must be accompanied by a signed purchase order. Travel time and expenses will be charged to this purchase order, along with service time if the cause of the failure is not covered by the warranty. No service will be performed on any product(s) unless full payment has been made for product(s).

WARRANTY CLAIM:

If Control Electronics, Inc. products are found to be defective in materials or workmanship within twelve (12) months of the date of shipment, they will be repaired or replaced with same product at the discretion of Control Electronics, Inc. at its place of business at no charge to the buyer. The defective product(s) must be sent, freight prepaid, to the ship-to address on the front page of this manual for warranty claim. All claims must be made in writing. Enclose a brief description of problem, person to contact, phone number and return ship-to address. Product(s) received without this information may not be processed on a timely basis.

If warranty and/or product(s) is not acceptable to buyer, please contact Control Electronics, Inc. and/or return product(s) unused for credit. This action must be made within 60 days from ship date from Control Electronics, Inc. Installation of product(s) or non-response within 60 day period indicates the buyers acceptance of product(s) and above warranty.

NOTE

This manual covers both the PDS-360 and PDS-360DX Flowmeters. The PDS-360DX Flowmeter is the same as the PDS-360 system with the following exceptions.

The PDS-360DX system does not have:

- 1] Relay Outputs - no alarms or Sampler pulse
- 2] No Clock or Date
- 3] No RS-232 output port
- 4] No Data Logging

This will be noted in the manual by - N/A on 360DX.

You may want to copy the following numbers from the upper left corner of the printed circuit board inside the enclosure for future reference. These numbers should be available if calling Control Electronics for tech support.

Serial Number: _____

Software Version: _____

Model Number: _____

INTRODUCTION

Control Electronics model PDS-360 Ultrasonic Open Channel flowmeter is a microprocessor controlled, non-contacting flowmetering system designed to accurately measure liquid flow through any standard primary flow device. The PDS-360 flowmeter has been designed with the user in mind, allowing for simple, intuitive set-up through a menu driven programming interface. Control Electronics has been designing and manufacturing Ultrasonic type flowmeters since 1980.

In theory, the PDS-360 system transmits high-frequency sound pulses from the sensor 4 times a second. The sound pulse travels through the air toward the liquid flow surface and reflects back as an ECHO return. The system calculates the elapsed time of echo return. The elapsed time is directly related to the distance the flow surface is from the sensor and is used, along with a temperature measurement, to calculate an accurate Depth-of-Flow measurement. The system makes these measurements continuously and without contact to the flow. Depth-of-Flow is then converted to flow rate indication and totalization through the built-in mathematical conversion equations for the Primary Flow Device selected by the operator.

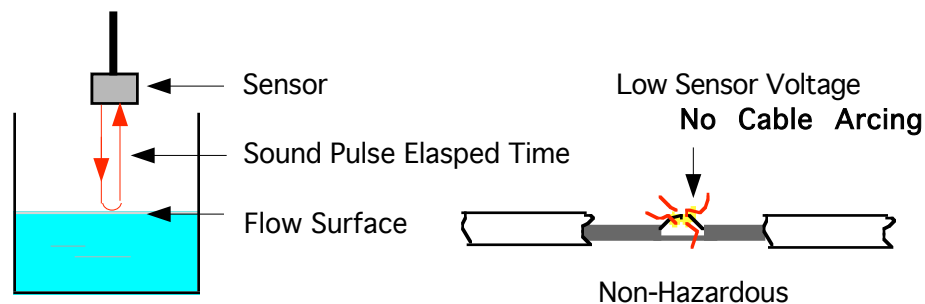

The Sensing element is a non-contacting probe capable of transmitting and receiving high-frequency sound waves. The Sensor requires less transmit power than most other systems. Approximately 24 to 60 volts peak-to-peak is required as opposed to some manufacturers that use as much as 400 to 1700 volts to pulse their Sensors. The higher voltages are hazardous to personnel and explosive atmospheres. Additionally, the PDS-360 Sensors unique design reduces both the dead-band (minimum range) and the signals beam spread. Two important considerations when monitoring flows in a flume with a narrow throat and approach section or manholes with low ceilings. The PDS-360 sensor, model US70TC is suitable for Class 1, Div. 1, Groups C & D and Class II, Div. 1, Groups E, F & G environments.

All PDS-360 circuits are protected in a NEMA 4X corrosion resistant fiberglass enclosure with a clear polycarbonate hinged cover for easy viewing of the flow indications.

After installing the flowmeter and Sensor, the operator will find the PDS-360 Flowchart in the back of this manual extremely helpful in navigating through the many options and features of the flowmeter.

INSTALLING THE FLOWMETER

The PDS-360 Flowmetering system is easy to install. Adherence to all installation instructions will result in successful operation of your system. If any deviation must be made from the prescribed installation procedures, please call our service department for change approval. Failure to install your system properly could lead to operational problems and become costly if a service technician is required on site to remedy. We suggest you read the entire manual to familiarize yourself with the equipment before installing.

1. Controller Installation

The PDS-360 electronics controller is housed in a NEMA 4X fiberglass enclosure. This enclosure is UL listed and rated as being water-tight, dust-tight and corrosion resistant. However, care should be taken in selecting a location that will offer protection from rain, chemical spills, extreme temperatures etc.

The electronics enclosure is suitable for outdoor installation, but it is recommended that the enclosure be mounted indoors or in a fiberglass shed located next to the measuring site. If the instrument has to be located outdoors, provisions should be made to maintain a temperature range between 25°F and 120°F within the enclosure. For cold locations, our optional Heater and Thermostat should be purchased. This option can be installed at any time by the user. In warmer climates the enclosure should be mounted away from direct sunlight or a sun shade should be provided.

IMPORTANT

On a hot day, direct sun light could damage the LCD display and raise the internal temperature of the enclosure above ambient temperature causing malfunction and/or possible damage to the unit. A Sun Shade should be provided.

The PDS-360 Electronics requires a 120 VAC power source. Though the PDS-360 flowmeter is designed to minimize electrical noise interference you should avoid installation in locations near equipment that may be electrically noisy or instruments that generate R.F. (radio frequency) noise such as SCR controlled equipment (i.e. variable speed controllers). This will minimize any potential problems.

The enclosure may be located up to 1500 feet from the measuring site. It is recommended that you keep the distance as short as possible. Metal conduit will be required between the measuring site and controller (note: do not attach metal conduit to sensor. **Maintain at least 3 foot separation for best results.**) electronics for the Sensor cable to run through. **It is important that no other cables run in this conduit.** Cable lengths less than 50 feet may be run in PVC conduit if there are no other AC signal wires in close vicinity.

Once a suitable location has been selected for the controller, carefully screw mount the enclosure as shown in figure1. Be sure to allow room for the conduit entrance to the enclosure as shown.

→ All conduit entrances must be made through the bottom side of the enclosure.
Do not enter through the top. This could cause possible water damage from leaks if the enclosure is rained on or hosed down. Separate conduits should be provided for 120VAC power source (conduit not required if supplied with optional AC power cord), output signal wires (4-20 mA., relay outputs etc.) and Sensor cable.

Protect the electronics circuit card from damage when punching holes in the enclosure for conduit entrance. The circuit card may be removed from the enclosure by removing the four retaining screws (along the top and bottom edge of circuit board) and unplugging the ribbon cable. A GREENLEE punch is recommended for punching the holes.

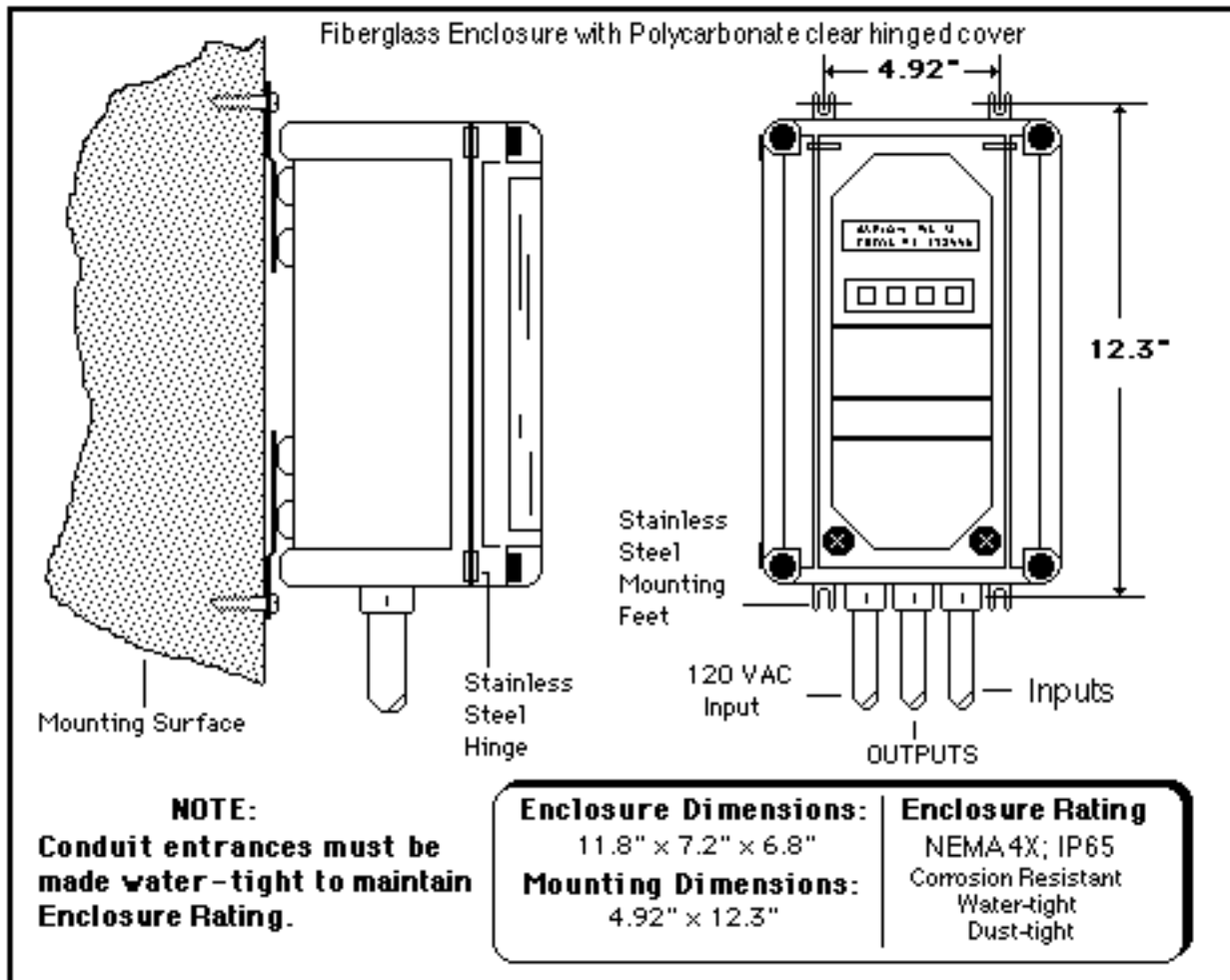

Figure 1.

Enclosure Installation In General....

- 1] Mount enclosure in a suitable location as described above. DO NOT locate in a confined or hard to reach area.
- 2] All conduit/wire entrances should be made at bottom of enclosure.
- 3] Conduit/wire entrances should be watertight to maintain enclosure rating.
- 4] Do Not mount enclosure in direct sun light. This could overheat the unit on hot days. A sun shade should be considered.

2. Sensor Installation

The Sensor location over the Primary Flow Device (flume/Weir etc.) is very important so the PDS-360 can accurately measure the flow. The location of the measuring point over the flow device varies with the type of flow device used. Refer to flow device manufacturer instructions.

Three most widely used flow devices are:

- 1] **PARSHALL FLUME:** Mount the Sensor $2/3$ of the distance upstream from the start of the throat section and the beginning or edge of flume.

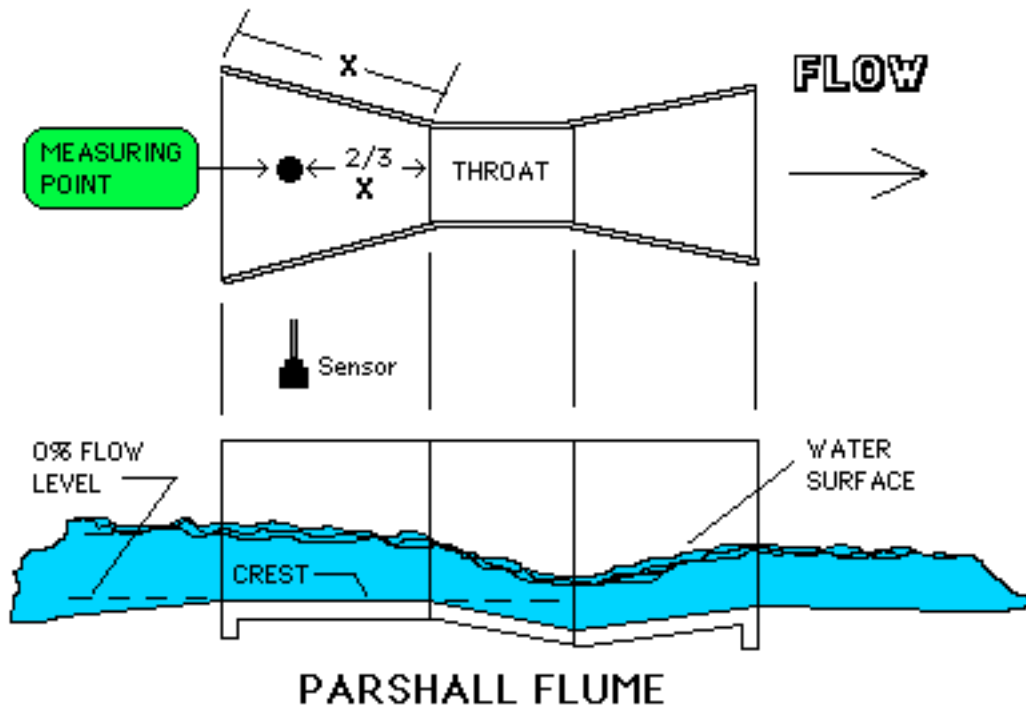

- 2] **PALMER-BOWLUS FLUME:** Mount the Sensor $1/2$ the flumes diameter ($D/2$) upstream from the start of the throat section.

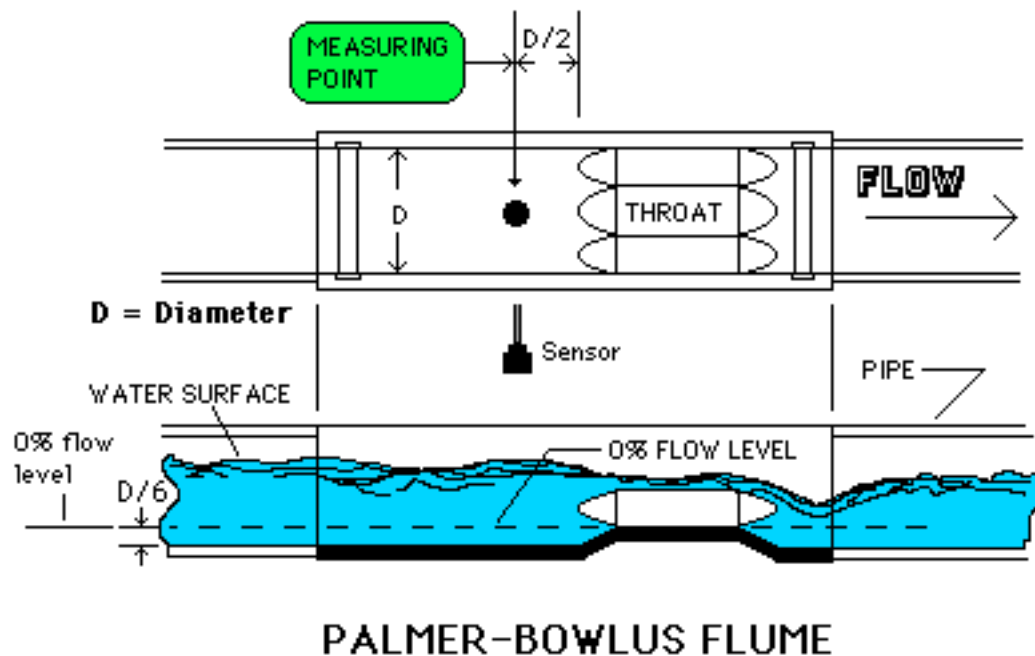

- 3] **V-NOTCH/RECTANGULAR WEIRS:** Mount the Sensor before the Weir plate a distance of at least 4x the maximum flow depth to be measured. DO NOT mount the Sensor over the Weir plate or the waters drawdown.

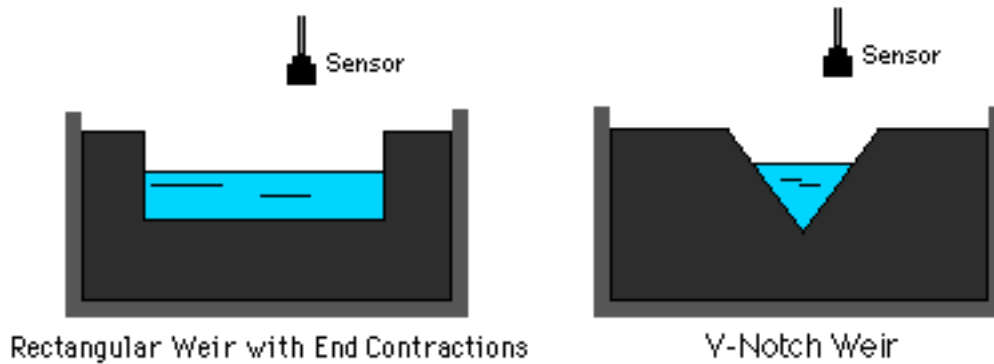
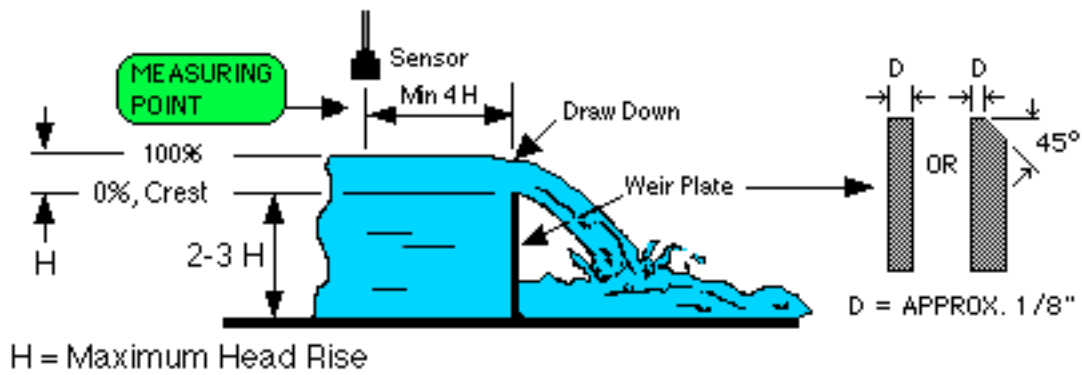

Sharp-Crested Rectangular and Y-Notch Weirs

Using A Stilling Well

A stilling well may be used if there is difficulty in measuring the flow level due to turbulence, thick foam etc. The stilling well must maintain a smooth inside surface for best results. Eliminate any gasket protrusion if two sections of pipe are joined to form a longer pipe. We recommend PVC pipe, at least 8 inch diameter or greater for the stilling well. Be aware the water in the stilling well may freeze in winter causing erroneous readings.

If there is any question about the orientation of the Sensor, contact the flume/weir manufacturer or our service department.

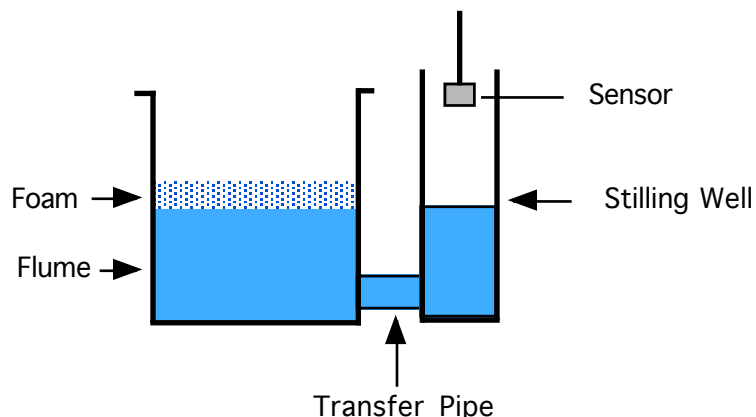

The Sensor is provided with at least 30 feet of cable (standard). An electrical non-corrosive plastic junction box should be located near the Sensor to allow splicing of its cable to additional cable length, if required. Use supplied cable (optional) or twisted pair shielded (Beldon# 8451 or equal) for the sensor connection.

IMPORTANT

It is Mandatory that the cable be ran in a PVC conduit using PVC watertight fittings, junction box etc. for the first 2 to 3 feet from the Sensor. If the Sensor is mounted to metallic pipe, fittings or bracket the flowmeter may not work !!

The cable running from the junction box to the electronics must run in a metal conduit for lengths greater than 50 feet. This conduit must be committed only to this cable. Running any other cables in this conduit will very likely interfere with the flowmeters operation.

Mount the Sensor with the supplied PVC Union Joint over the prescribed measuring point in the flume or Weir (see page 4-5) using Control Electronics PVC Sensor Mounting Bracket (optional) or a Sensor mounting bracket of your own construction (see figure 2). Be sure the Sensor mounting bracket is made from PVC, **not metal**, and is plumb and secure, not just dangling over the flume. Make certain that the elevation of the Sensor allows for at least a 12.0" DEAD BAND (12.0" above maximum flow depth anticipated plus at least another 2 inches (recommended)).



DO NOT overtighten the Sensor to the bracket. This could cause extended Sensor ring-time that may interfere with ECHO signal.

Sensor Installation In General.....

- 1] Determine Sensor location over Flume/Weir (see page 4-5).
- 2] Install PVC Sensor Mounting Bracket. **DO NOT** use any metal components on bracket. Refer to figure 2. Make sure Sensor support is plumb and secure. Use PVC Union Joint for best results.
- 3] Make certain that the elevation of the Sensor allows for at least a 12.0" DEAD BAND (12.0" above maximum flow depth anticipated plus at least another 2 inches (recommended)).
- 4] Run PVC or metal conduit from Sensor location as described above to flowmeter enclosure.
- 5] Pull Sensor cable through conduit being careful not to nick or puncture the cables outer insulation.
- 6] Make any splices to sensor cable required. Use wire nut, liquid tape (to water proof) and electrical tape to make splices.
- 7] Do not overtighten Sensor to Bracket. This could cause extended sensor ring time that may interfere with ECHO signal.
- 8] Seal and tighten all junction box lids and conduit connections to prevent water infiltration.

IMPORTANT

Be certain to make a good water tight entrance with the conduit to maintain the NEMA 4X rating. The conduit should also be plugged with electricians putty to prevent moisture migrating from the Sensor to the enclosure and vice versa. This will help to prevent condensation forming in the conduit and enclosure.

Connect the Sensors cable to the Three (3) pin terminal barrier strip on PC-548 Open-Channel flow card marked SENSOR. The Red wire to RED, Black to BLACK and bare (ground return) to BARE. Refer to figure 3. Cable type: Beldon #8451 or equal - twisted pair shielded.

120 VAC input

120 VAC power must enter through the bottom side of the enclosure in its own committed conduit (not required if supplied with optional AC power cord). Connect AC power to the terminal barrier strip marked AC INPUT. DO NOT allow the AC wires to lay all about in the enclosure. Keep as short as possible to avoid AC interference. 14 gauge wire is preferred over a heavier wire that may put unnecessary stress on the terminal barrier strip. Fuse power line if needed so as not to exceed wire capacity. The flowmeter has an on board 0.5 amp fuse.

AC OUT

This provides a switched 120 VAC power to control an external recorder or optional 60 watt Heater/Thermostat that operate in conjunction with the flowmeter.

NOTE: The flowmeter has a .5 amp 5mm fuse, 1 amp with heater. It may be necessary to increase the fuse rating to accommodate external devices. Max rating should not exceed 3 amps.

4-20mA outputs

There are two independent 4-20mA. outputs, individually adjustable. They are used to control samplers, setpoint controls, recorders, chlorinators etc. The two analog output signals are FLOATING outputs (both the '+' and '-' terminals have their potential above system ground) and are DC isolated from electrical ground. The signal outputs are connected as shown in figure 3. Polarity must be observed through the entire control loop for proper operation. Maximum loop resistance for each output is 1000 ohms. **Twisted pair shielded wire should be used, Belden #8451 or equal.** Ground wire (bare wire) may be connected to ground ($\frac{\perp}{\perp}$) on terminal barrier or remote device. **Make connection only at one end.**

Note: the 4-20 mA output is fused. Fuse is rated for 62 mA. Do not exceed 250 mA.

If 12VDC battery operation is used, you must connect the '+' lead on the 4-20 ma loop to '+' 12V. Max loop resistance should not exceed 500 ohm.

RELAY #1, 2, 3 and 4 outputs (N/A On 360DX)

Relay #1 thru #4 are independently programmable alarm setpoints used for alarming and control. They are 5 amp, 220 VAC contacts with associated LED status indicators on board. Use wire suitable for electrical load to be carried by contacts. Fuse line if needed so as not to exceed contact rating.

RELAY #5 output (Programmable Pulse, N/A On 360DX)

Relay #5 is a programmable pulse output used for pulsing a remote totalizer counter or for Sampler control. The output is a dry contact rated at 5 amp, 220 VAC. Closure duration when programmed count is met is 250ms. (milliseconds).

ZERO METER input

A **dry contact closure** across ZERO METER input will force the Flowmeter to go to a preprogrammed percentage of flow value as entered by the operator. (ON ECHO LOSS GO TO in program section). This will also display ECHO LOSS warning.

UNREG DC, \pm (ground) , 12 VDC (Bat), 24 VDC

These inputs/outputs provide DC power for optional accessories or allow for battery operation of the flowmeter. UNREG DC is both an input and an output. When AC power is applied to unit, an unregulated voltage of approximately 16~18 VDC will be found at this point between UNREG DC and GROUND (\pm) and 12 VDC between 12VDC and GROUND. 24 VDC is available between '+' of the 4-20mA output and ground (\pm). This may be used to power customer options. Max current draw should not exceed 150 mA.

Note: 4-20 mA fuse is 62 mA. May need to be increased to a max of 250 mA. If using 12VDC operation, you must connect '+' lead of 4-20 mA loop to 12VDC.

BATTERY ONLY OPERATION

If the flowmeter is going to operate from a battery only (no AC power), a standard 12 volt gel cell battery may be connected between 12VDC and Ground on the terminal barrier. The plus '+' of battery to 12VDC and the negative '-' to GROUND (\pm). 6 amp hour battery recommended .. max run time approx. 48 Hr.

BATTERY BACK-UP OPERATION

If battery back-up is desired to maintain operation of the flowmeter in the event of a power failure, you may connect a standard 12 volt gel cell battery of at least 1 amp hour or greater at the 12VDC (Bat) connection (plus '+') and ground (\pm) (negative '-') on the terminal barrier. The flowmeter will maintain a charge to the battery when AC power is applied. **NOTE: battery back-up is not required to retain the programming.**

IMPORTANT

The power switch on the circuit board does not switch the battery supply nor does the fuse offer any protection. Power is applied as soon as the battery is connected to the terminal barrier. We recommend you install a switch and an in-line 3 amp fuse for protection if no on-board fuse is provided for battery.

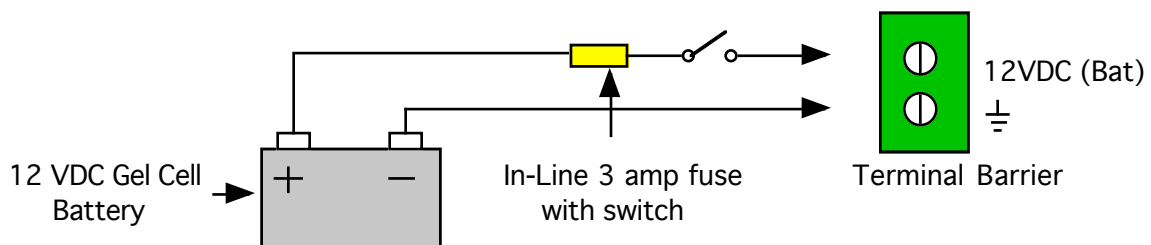

4. ADJUSTMENTS AND CONTROLS

There are very few adjustments that can be made on the PDS-360 system. Do not attempt to make any if you do not understand their purpose. To do so may void your warranty and result in a costly service charge.

Please note: The following adjustments/calibrations are factory set and should not be touched unless authorized by service technician from Control electronics.

Ultrasonic Transmitter / Receiver Card

Refer to Figure 4

GAIN

The gain has been factory set. Normally the GAIN setting does not need to be touched. Typical adjustment is set to one half of its turn. If adjustment needs to be made, first make certain that the Sensor is plumb to the flow surface. Keep in mind that changes in the GAIN setting may effect the apparent calibration and you may have to offset the calibration under **MISC Settings** mode - **RANGE = xxx.xx Cal Factor = 1.000** in the programming. Too much or too little GAIN may cause the unit to respond to unwanted noise or cause loss of signal.

IMPORTANT

Do Not mistaken Sensor mounting problems for electrical noise problems. Always check installation first before making any adjustments.

THRESHOLD

The THRESHOLD is factory set. Full CW or CCW will cause loss of signal. Increasing (CW) the THRESHOLD may help in rejecting unwanted electrical noise. If the meter appears erratic try increasing the THRESHOLD. Note: Sensor mounted to any metallic fittings, braces etc. may cause problems that may not be resolved by GAIN or THRESHOLD. See Sensor Installation and troubleshooting in back of manual.

PC-548 Ultrasonic Xmit / Receive Card

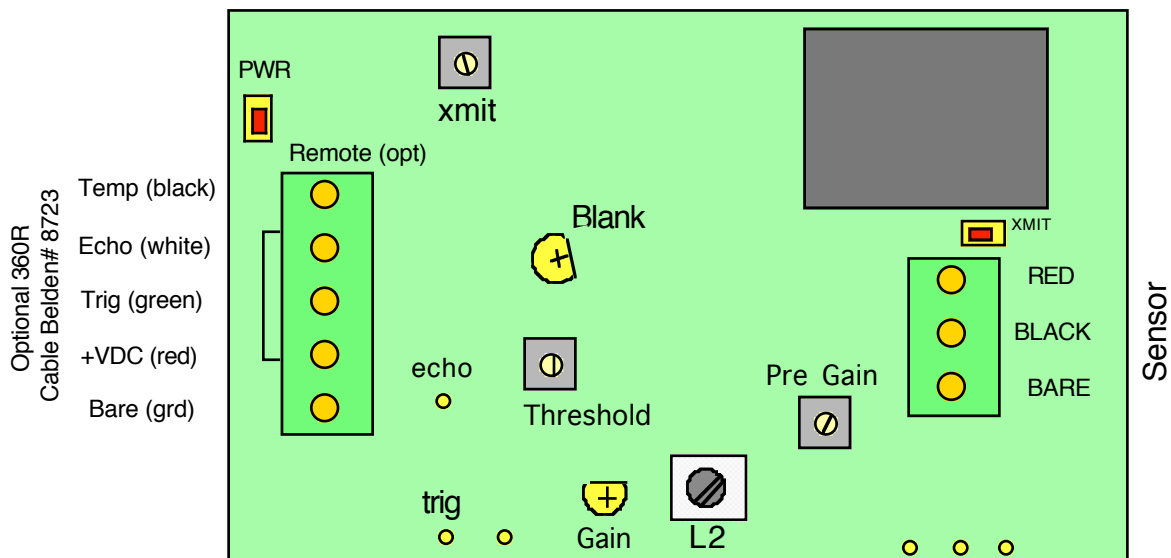

Adjustments shown in their NORMAL position

Figure 4.

XMIT / L2

XMIT is for setting the transmitt frequency (40kHz.) and L2 (tuning coil) for setting the receivers frequency - Factory Set. The XMIT pot is typically set to approximately 1/3 to 1/2 of its turn from CCW position. Slight adjustments of these settings will affect the gain of the flowmeter.

BLANK

This setting BLANKS the transmit pulse and ringing in the sensor - Factory Set. Caution: too much blanking may cause close echo signals (12 to 16 inches from sensor) to be blanked and not processed.

PRE GAIN

Factory set and should not be touched. CW increases GAIN.

XMIT LED

The XMIT LED indicates a pulse has been sent to the sensor. This should pulse the same time the RUNNING LED pulses on the main circuit board.

Main Circuit Board

Refer to Figure 3, page 8, for the following adjustments.

Note: 4-20 mA adjustments have been factory set and should not require any adjustment.

4 mA.

The 4 mA. adjustment is used to set the 4-20 mA. current output loop to 4 mA. This should be set before the 20 mA. adjustment. This will prevent any apparent interaction of the 4 and 20 mA. adjustments. You can Simulate 0% output using the **TEST 4-20 mA OUTPUT** feature under **MISC Settings ?** mode in the programming to set the 4 mA. output. Outputs #1 and #2 may be adjusted at this time. Note: output 1 and 2 are independent and have no affect on each other when adjustments are made.

20 mA.

Adjust the 20 mA. control for 20 mA. output on the 4-20 mA. current output loop. Simulate 100% output using the **TEST 4-20 mA OUTPUT** feature found under **MISC Settings?** mode in the programming. Note: output 1 and 2 are independent and have no affect on each other when adjustments are made.

4-20 mA. DAMPING

User Adjustable ... Adjust clockwise to increase the 4-20 mA. Analog Output Dampening for steadier chart recordings. DAMP adjustments 1 and 2 are independent of each other.

ON/OFF Switch

Applies AC power to the circuit board and AC out to the AC OUT on the terminal barrier. Note: this switch does not control battery if connected.

120/220 VAC

Install or remove appropriate jumper(s) to change operating voltage to 120 or 220 VAC. Note: this is factory set. Jumpers are located under left-bottom corner of power transformer.

LED's 1 thru 5 (PDS-360 only)

These LED lights will lite when associated relay is energized. LED 1 thru 4 represent setpoints. LED 5 represents the programmable pulse to a sampler or remote counter.

RUNNING LED

Each time the system makes a flow measurement, this LED will flash. Typical rate is 4 times per second. This is considered normal operation and should be flashing steadily.

Note: when downloading data log this LED will appear erratic.

NO SIGNAL LED

If the ECHO signal return is lost or not processed for at least 12 continuous seconds, this LED will light and a warning will be displayed. The LED will flash erratically under turbulent flow conditions or a misaligned sensor mounting. This is normal. The percent of ON/OFF will be an indication of signal strength. See troubleshooting guide in back of manual if this LED is 'ON' steadily.

CLK/MEM 3V Bat

This battery is for retaining programmed information and keeping the clock running when power is turned OFF. The battery should last for approximately 8 to 10 years under normal operation. You may replace the battery when power is ON by pulling the battery out of its holder and replacing it with a '#CR2025' 3 volt lithium battery.

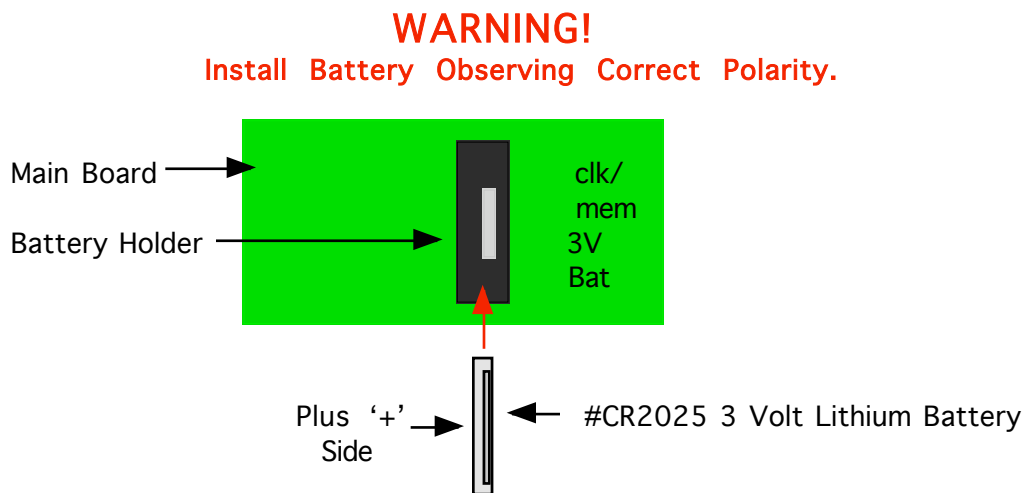

WARNING!!

If battery is removed when power is 'OFF', all programming and clock / date will be lost. You will need to restart the system as described in the Programming Flowchart in this manual by using the 'SHIFT' button to RESET the meter to defaults and then reprogram.

STARTING UP THE FLOWMETER

Once all installation procedures have been completed, the PDS-360 Flowmeter is ready to be powered up. But before doing so, it is advisable that you go back and check your installation to ...

Before Applying Power Quick Check List

- 1] confirm that all wire connections are correct and secure, particularly the AC power input with correct circuit breaker size.
- 2] confirm that the sensor has been installed properly using the correct type of cable (Belden# 8451 or equal) and any splices made to the sensor cable are correct, secure and moisture tight (use liquid tape, available at most electrical and hardware stores).
- 3] make sure all conduit entrances to the enclosure are watertight. Use electricians putty to plug conduits to prevent condensation and gases migrating to enclosure.
- 4] measure the distance from the sensor face to the zero flow point (0%) in the flume/weir. You will need this value in inches when programming.

You are now ready to power up the flowmeter.

TURNING POWER ON

Turn AC power Circuit Breaker ON back at the electrical panel if needed. Switch the POWER ON to the flowmeter by switching the small toggle switch on the lower left of the main circuit board to ON.

Once power is applied, the flowmeter will power up and display a few banners indicating manufacturer and software revision number. Before shipping, the flowmeter was set to factory defaults and should now display DEPTH of flow and GPM.

Please note: The values displayed will most likely be incorrect, possibly showing a negative depth. This is normal. The flowmeter has not yet been set up to your application.

INITIAL RUN MODE DISPLAY AND KEYPAD LAYOUT

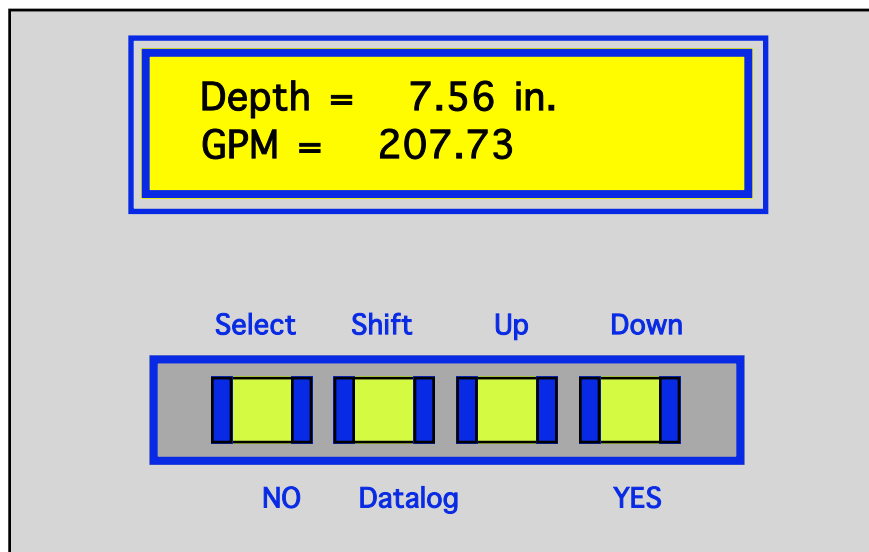

Wait approximately 15 seconds to make sure the meter does not display any warnings with respect to ECHO signal or TEMPERATURE. If warnings are displayed, check wiring and see troubleshooting guide in back of manual.

The Flowmeter is now operating. The 'RUNNING' LED light on the main circuit board should be flashing (approx. 4 times per second) and the 'NO SIGNAL' LED should be OFF or intermittent if flow is turbulent. Some relays may energize (N/A on PDS-360DX), depending on the default settings.

PROGRAMMING THE FLOWMETER

You can now begin programming the flowmeter once the STARTUP procedure above has been completed successfully. The keypad on the front panel is used for selecting the various RUN MODE indications and PROGRAMMING MODES of the flowmeter. Use the SELECT button to scroll through the program selections, selecting NO/YES where needed. To change any value, use the SHIFT button (moves cursor under digit you want to change), UP and DOWN buttons (to change the value of the selected digit).

When in the RUN MODE, press the UP or DOWN button to display the RUN MODE parameter you desire. The 4-20 mA. output is not affected by the selection of any RUN MODE window.

Selections:

GPM .. TOTALIZER or MGD .. TOTALIZER

Flow may be displayed in GPM (gallons per minute) or in MGD (million gallons per day) units with TOTALIZER count. The TOTALIZER is an 8 digit counter that indicates the total accumulated flow in gallons to date. The total will be equal to the count displayed times the multiplier (i.e. x100) indicated. The multiplier may be programmed under the **SET FLOW PARAMETERS** section.

DEPTH .. GPM

DEPTH indicates the measured HEAD (depth) of water as it passes through the flume or over the weir plate. DEPTH may be displayed in inches or feet. This reading is used in the equation for the selected primary device to calculate the GPM flow reading and finally a total accumulated flow.

Depth = ZERO% distance - SENOR to FLOW SURFACE distance (Range)

Note: if the flow level drops below the ZERO % setting, the DEPTH will be displayed as a negative number.

i.e. DEPTH = - 2.34" (means 2.34" below the programmed ZERO % point).

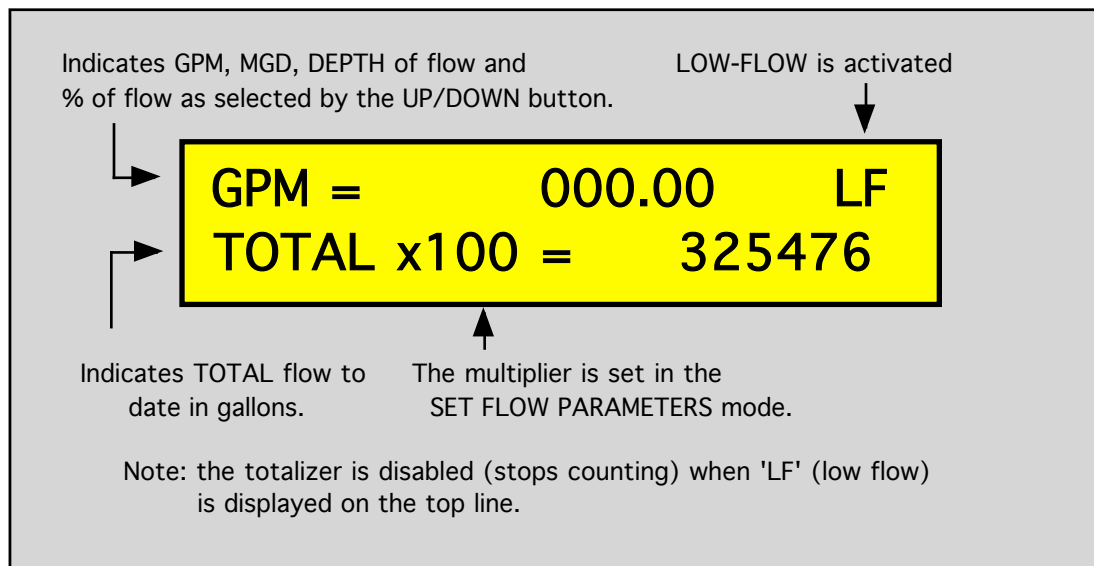

TYPICAL RUN DISPLAY

Flow % .. TEMPERATURE

FLOW % indicates the percent of flow as found on the 4-20 mA. output #1. The output is scaled by the **SCALE 20 mA. OUTPUT #1** under the **SET FLOW PARAMETERS** mode in programming.

The outside temperature at the Sensor is also indicated. The temperature is in degree fahrenheit $\pm 3^\circ$. The flowmeter must have a temperature reading to do flow calculations. If the probe is damaged or not used, you must manually turn the probe 'OFF' and enter a temperature under **MISC Settings ... Temp Probe ON / OFF**. If the Temperature Probe is 'ON' and the system senses a probe failure, the flowmeter will automatically use the default temperature you entered in **Enter Outside Temp** if you select **Temperature Probe is OFF**. Factory default temperature is 60° F. A TEMP PROBE failure warning will be displayed.

Note: Temperature may indicate as much as 10° warmer than the ambient air if the sun is shining directly on the sensor.

LF (Low Flow)

If the letters LF are displayed in the top right corner of the display, this indicates that the LOW-FLOW SHUT-OFF is activated. When the GPM flow calculated by the flowmeter is below the **LOW FLOW SHUT OFF** GPM setting programmed by the operator, the %, GPM, MGD readings and analog outputs (i.e. 4-20mA) will be forced to zero. The totalizer also stops counting at this time. The DEPTH display will continue to indicate the flow depth as measured by the flowmeter.

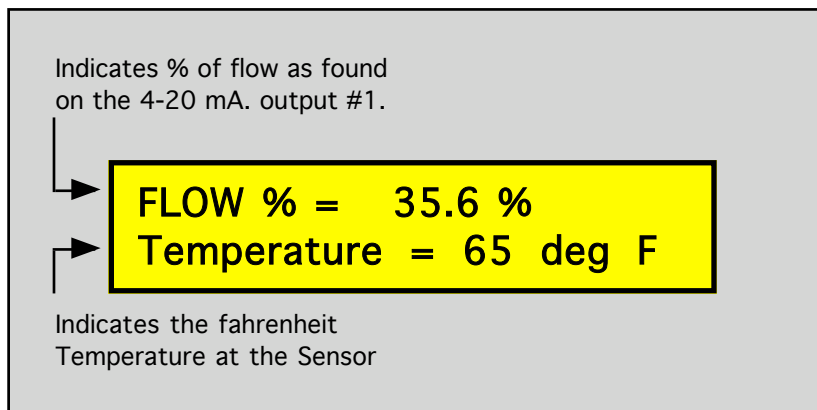

BEGIN PROGRAMMING

The programming of the flowmeter is accomplished by first pressing the SELECT button. You will be asked if you want to **GO TO PROGRAM MODE?** If you select YES you will be asked to **ENTER YOUR PASS CODE**. Enter the PASS CODE using the SHIFT, UP and DOWN buttons. If the wrong PASS CODE is entered, the display will return to the RUN MODE last selected.

Note: The flowmeter leaves the factory with pass code '0000'.

Press the SELECT button again. You are now asked **CHANGE PASS CODE?**. If you like, you may change the pass code at this time by using the SHIFT, UP and DOWN buttons. If you change the pass code

IMPORTANT

Remember your new PASS CODE !!!

If you forget your pass code and can not enter the programming section, you will need to call the factory at 610-942-3190. Please have your flowmeters serial number available. It is found on the upper left corner of the main circuit board.

Press the SELECT button and you will be asked **SET PRIMARY DEVICE?** Select YES to enter PRIMARY DEVICE selection. Use the UP/DOWN buttons to select the type of primary device you are using.

Refer to the PROGRAM FLOWCHART in this manual for navigating through all the programming functions.

Press SELECT and enter the size of the Primary Device.

Next press SELECT until asked **SET FLOW PARAMETERS**. Select 'YES'. Enter the measured **ZERO FLOW DISTANCE** (distance from sensor face to zero flow - crest - of flow device) point using the SHIFT, UP and DOWN keys. Press SELECT. Enter the **SET SPAN (max head)**. Refer to figure 2, page 6.

Note: If the ZERO FLOW DISTANCE value is changed, the SPAN will automatically set itself according to SPAN = ZERO DISTANCE setting less 12.0". You may change the SPAN to any value that is less then the value displayed. Minimum SPAN is 1.00".

Set the **SCALE 20 mA. OUTPUTs #1 and #2** to set the 4-20mA outputs to a remote recorder if needed. For example, the recorder charts are printed 0-500 (GPM). Set the OUTPUT for 000500.00 GPM.

Note: Output #2 may be scaled for Gal/Min (GPM), Flow Depth (inches) or Temperature (Deg) ... **Set Output #2 for..** in programming. Output #1 is by default, Gal/Min (GPM).

This completes the basic calibration.

Proceed through the PROGRAM MODEs referring to the PROGRAM FLOWCHART, page 27, to help you navigate through the program section.

SETTING/TESTING ... 4-20mA OUTPUTS

There are two (2) 4-20 mA. outputs on the PDS-360 flowmeter that can be set independently and tested using the **TEST 4-20mA OUTPUT?** function under the **MISC Setting....** mode. Enter the TEST 4-20mA OUTPUT by selecting 'YES'. The 4-20mA outputs should go to 4 mA. or 0%. The display will read ...

4-20mA Output = 00%.
Done +25 +10 -10

(Note: the 4-20mA outputs are damped by the **4-20mA Damping** adjustments on the main circuit board. You may want to turn the adjustments fully CCW for quick response of output while testing).

- 1] Adjust the '4 mA.' potentiometer adjustment of output #1 and #2 (see figure 3, page 8) for 4 mA. output.
(Note: perform the 4 mA. adjustment first to eliminate any interaction between the 4 and 20 mA. adjustments).
- 2] Press the SHIFT button 4 times to simulate 100% or 20mA.
(Note: Pressing the SHIFT button adds 25% to the output; the UP button adds 10% and the DOWN button minus 10%. By using the SHIFT, UP and DOWN buttons, you can increment and decrement the output in 5% increments).
- 3] Adjust the '20 mA.' potentiometer of each output for 20 mA. output.
- 4] Repeat steps above using the Keypad to simulate an output and confirm the 4-20 mA output.
- 5] When completed, adjust the **4-20mA DAMPING** on main circuit board to desired 4-20mA response.
- 6] Press SELECT (Done) when completed to exit simulate of 4-20mA output.
- 7] Scale each 4-20 mA. output under **FLOW PARAMETERS SCALE OUTPUT #1 SCALE OUTPUT #2**. Note: Output #2 may be set for GPM, Flow Depth in inches or Temperature in Deg F.
See FLOWCHART Page 29.

Note: if the 4-20mA output is not responding correctly or is reading above 22mA., the output is most likely defective and will require repair or the loop resistance is too high. Do not adjust the 4 and 20mA adjustments to correct for large discrepancies (more than 3 mA.).

SAMPLER OUTPUT ... Relay #5 (N/A on 360DX)

The SAMPLER PULSE output, Relay #5, is used to pulse a remote Sampler or counter. It is programmed under the **SET RELAY OUTPUTS?** mode ...

Relay #5 Sampler Pulse ... 1 Pulse = 000000 gal.

Example: if you need to sample your flow every 1000 gallons you would program the **SAMPLER PULSE** rate for 001000. If a remote counter needs to be pulsed, enter a multiplier i.e enter 000100 for x100. A programmed setting of 000000 gal disables the pulse output.

The relay will close for a duration of 250 ms. (= 1/4 sec) when the count is reached. The function will automatically reset itself for the next count. The relay contact is a dry contact rated 5 amp, 220 VAC. An associated LED light will flash when the Sample is made.

After setting the SAMPLER output, you may choose to log the time and date each sample is taken by selecting 'YES' when asked **LOG SAMPLER EVENT?** The EVENT LIST can be viewed by downloading the data to a PC/Lap Top through the RS-232 output. See using the RS-232 Output.

RELAY OUTPUTS .. Relay 1 ~ 4 (N/A on 360DX)

The PDS-360 has four (4) independently programmed alarm relay outputs. The programming is performed under the **SET RELAY OUTPUTS?** mode. Each

Relay output has a separate ON and OFF setting for differential control of pump ON and pump OFF or valve open/close etc. The program values are in GPM. The relay contacts are dry contact closures rated 5 amp, 220VAC. An associated LED will light when the relay is energized.

Note: while in the program mode, the relay outputs will not be affected by any program change. Once you are back in the RUN MODE, the new values will take affect.

When a relay switches state (i.e. OFF to ON, ON to OFF), the relay number, time and date will be logged in the EVENT LIST. The EVENT LIST can be viewed by downloading the data to a PC/Lap Top through the RS-232 output. See using the RS-232 Output.

TESTING THE RELAY OUTPUTS

(N/A on 360DX)

The relay outputs can be tested by going to **MISC Settings ? mode, TEST RELAY OUTPUTS?** Select 'YES'. The display will show

Test Relay #0
Done ON OFF Select

- 1] Use the DOWN button to Select the relay number (1 thru 5).
- 2] Press the SHIFT button to turn the selected relay 'ON'.
- 3] Press the UP button to turn the selected relay 'OFF'.
- 4] Press the SELECT button when 'DONE'.

The associated LED light will light when relay is energized.

Setting the Time and Date ***(N/A on 360DX)***

Under the **MISC Settings ?** Set the Time and Date using the SHIFT, UP and DOWN buttons. The Data Logging and 24 hour Summary uses the time/date for logging purposes. The time/date is generally set when it leaves the factory but should be checked.

Reset the Totalizer ... Data Log

Under the **MISC Settings?** you can RESET the Totalizer to zero and/or RESET (clear) the Data Log (N/A on 360DX) by selecting 'YES' when asked. It is best to do the RESETs when starting up the flowmeter or when the Time/Date have been changed.

Note: The EVENT LIST is not Reset by the Data Log RESET (N/A on 360DX).

Temp Probe ON/OFF ...

Under the **MISC Settings ?** you can disable (turn OFF) the temperature probe and enter a manual temperature for the flowmeter to use. This may be necessary to do if your temperature probe is defective.

If the flowmeter detects a defective or disconnected temperature probe, it will automatically use the entered manual temperature. This is considered the default temperature. You can enter a default temperature and still use the temperature probe by

- 1] Go to **TEMP PROBE ON/OFF** and press the UP or DOWN button until the flowmeter displays **Temp Probe is 'OFF'**.
- 2] Press SELECT button. You will be asked to **ENTER OUTSIDE TEMP.**
- 3] Use the SHIFT, UP and DOWN button to enter a temperature. This is also the flowmeters new default temperature.

Note: you can enter something other than the actual temperature (default temp). Enter the actual temperature only when the temperature probe is defective and/or you are not going to use the temperature probe.

- 4] Press the SELECT button to return to **TEMP PROBE ON/OFF ...**
- 5] Leave Temp Probe OFF if the temperature probe is defective or you are not using the probe. The flowmeter will use the default temperature you just entered.

- **OR** -

Press the UP or DOWN button to select Temp Probe is 'ON'
The flowmeter will use the temperature probe. If the probe fails or is defective, the flowmeter will automatically use the default temperature entered and display a warning. If the warning is displayed and you can not immediately correct the problem, return to this section and select **TEMP PROBE is OFF** until the problem is corrected, at which time you would return and select **TEMP PROBE is ON**

- 6] Press the SELECT button to continue.

Changing The Calibration Reference

Make a measurement from the Sensors face to the surface of the flow. Go to **MISC Settings....** mode in the flowmeter and check the **RANGE =** display value. This is the actual measurement the flowmeter is making. If the distance is not correct, use the SHIFT, UP and DOWN button to change the CAL FACTOR value. i.e. if the displayed value is found to be 2% low, enter a CAL FACTOR of 1.020 to increase value by 2%. If the displayed value is 1.5% high, enter a CAL FACTOR of 0.985. Changing the CAL FACTOR alters the microsecond reference used in the distance calculation to compensate for installation anomalies, sensor tolerances, atmosphere conditions etc. DO NOT attempt to correct flow indication unless you are absolutely certain that the instrument is incorrect.

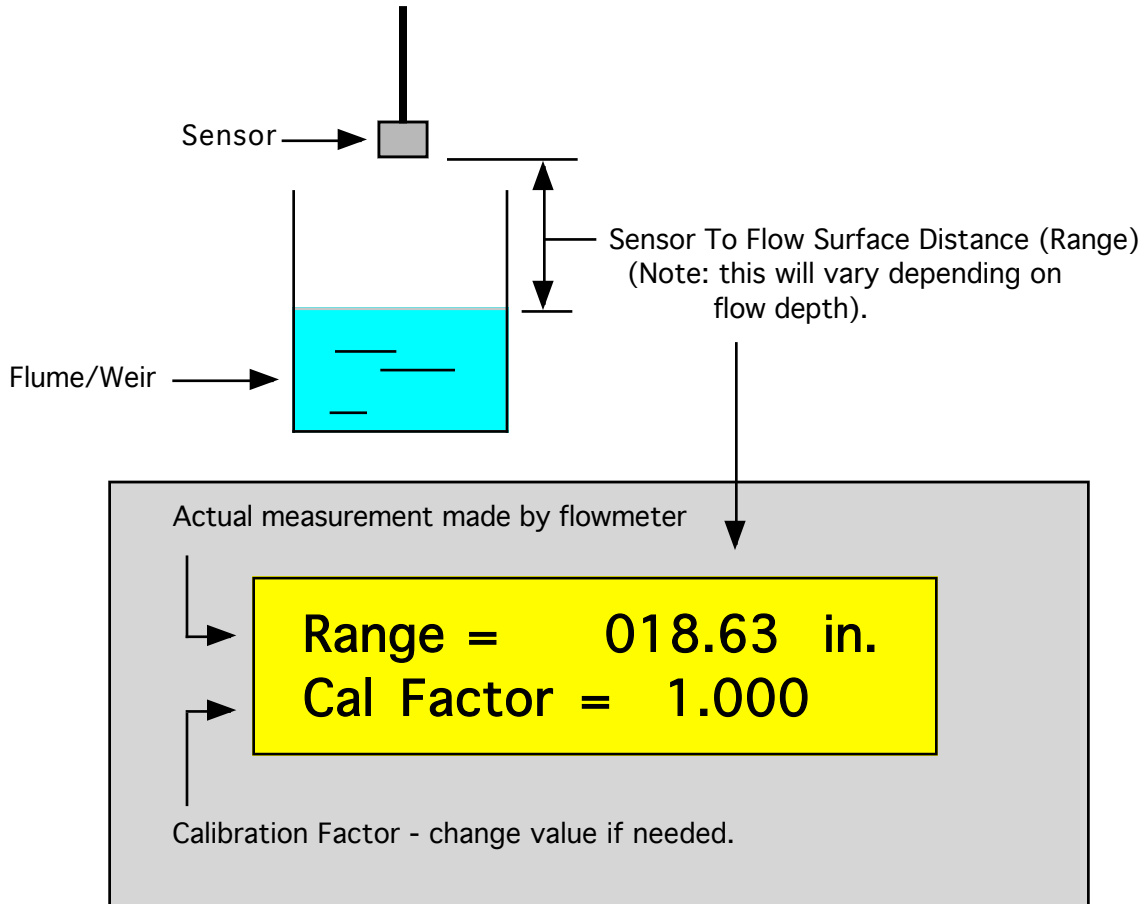

IMPORTANT

Be sure the Sensor has been installed properly over the flume or weir (see sensor installation), programmed data is correct, Temperature Reading is correct, all cables have been properly connected and your physical measurement is correct before making any CAL FACTOR change.

Data Logging (N/A on 360DX)

The PDS-360 Flowmeter continuously logs data as flow measurements are being made. Once filled, old data will be written over by new data (auto wrap around). The flowmeter has three (3) independent data log types. They are 1] a 24 hour flow summary; 2] average flow samples and 3] an event list. All data log may be downloaded to a PC/Lap Top for viewing using the RS-232 output (see using the RS-232 output). The 24 hour summary may be directly printed to a serial printer connected to the RS-232 output either on demand or set for AUTO print. The flow totals, Avg, Min and Max GPM for the past 6 months may be viewed at the flowmeter.

24 Hour Summary

The 24 HOUR SUMMARY data log keeps track of the days flow totals, the MIN, MAX and Average GPM flow rates and time they occurred for the past 6 months. The START time for the 24 hour summary may be set by the operator under the **Set Communications** section in the programming. The default setting is 12:00 midnight. The START time begins a new summary page with date and times. To view the 24 Hour Summary you must download the data to a PC/Lap Top computer using the RS-232 output. You will be able to select up to 6 months of data, preformatted for quick viewing and print out. (see using the RS-232 output for download instructions).

Viewing Daily Totals, Min, Max, Avg

The daily totals with Min, Max and Avg GPM flow rates can be found in the 24 Hour Summary described above or viewed at the flowmeter by pressing the SHIFT (DataLog) button while in the Run Mode. You will be asked 'View Data Log?' Press YES. The Date and Total gallons for that date will be displayed. (Note: Flowmeter will always begin with today's date. Today's date will show total gallons so far for the day.) Press the UP or DOWN button to select next or previous date; the SHIFT button to see AVG GPM, again to see MIN GPM and then MAX GPM. Press the SELECT button while viewing the TOTAL to EXIT the Data Log section. There are up to 200 days of Data.

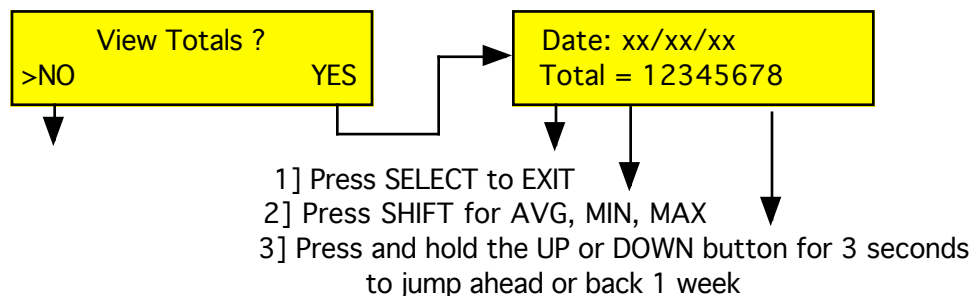

Print Daily Readings

If NO is selected in **VIEW TOTALS?**, you will then be asked **Print Daily Readings?** If NO, you will return to the Run Mode. If YES, you can select ...

Print NOW. You then will be asked number of days (up to 200). Press Select to begin printing to your serial printer. (Note: the flowmeter sends one data line to the printer and waits approximately 2 seconds for the printer to print before sending the next line. Printing a large number of days may take some time. Approximately 15 seconds per days data).

- OR -

Print AUTO. The flowmeter will display the time the 24 Hour Summary will print each day. (Note: this time is set under Set Communications. Make sure your printer is turned ON).

Average Flow Samples

The flowmeter may be set to log average flow rates, set under **Set Communications**. You can program the **Data Log Sample Rate** to sample flow every 1 to 99 minutes in 1 minute increments. If the setting is programmed for 00 minutes, the data log sampling is disabled.

When a sample rate is set, the flowmeter will average the flow rate from the previous log time to the next log time then save and time stamp it.

Example: the flowmeter is set to log data every 30 minutes. The last logged average flow rate was at 10:05 AM. The flowmeter will keep a running flow rate average from 10:05 AM to the next sample time at 10:35 AM at which time it will log the average flow rate and begin the next sample period. The flowmeter does not log instantaneous flow rates which can be misleading.

This data can be downloaded to a PC/Lap Top using the RS-232. The data will show DATE, TIME and FLOW RATE. You can also select the data to show a bar graph next to itself to see a visual trend.

Event List

The Event List logs the date, time and event type when it happens. Events types are ...

- | | |
|-------------------------|--------------------------|
| 1] System Restart | 8] Sampler Pulsed |
| 2] Entered Programming | 9] Reset Totalizer |
| 3] Echo Signal Lost | 10] Reset Data Log |
| 4] Echo Signal Returned | 11] Reset Event List |
| 5] Temperature Error | 12] Master Reset/Startup |
| 6] Relay #x ON | |
| 7] Relay #x OFF | |

The Events may be viewed by downloading to a PC/Lap Top using the RS-232 output.

Resetting The Data Log

The Data Log may be RESET (clear all data) by selecting YES when asked **Reset The Data Log?** under **Misc Settings**. Note: this does not RESET the Event List. This can only be Reset by doing a MASTER RESET to the meter.

Resetting The Flowmeter

If the SELECT or SHIFT button is held when power is applied to the flowmeter, then released, the user will have access to the flowmeters reset functions.

If SELECT is used, the user may reset the flowmeter by saying 'YES' to FACTORY DEFAULTS and 'NO' to USER PRESETS when prompted. The operator must now proceed to reprogramming the flowmeter.

Note: This reset will set the pass code to '0000'.

If the SHIFT button is used, MASTER RESET, it will do the same as above plus reinitialize the time/date and reset the Event List. It will be necessary to set the clock and date. Do this RESET if using the SELECT button above does not work.

The Resets can help recover from a processor crash or lockup due to lightning etc. The resets do not affect the totalizer or data log. The user may proceed to resetting the totalizer and /or data log in the PROGRAMMING section and setting the time/date if needed.

If The Flowmeter Should Lockup or Crash

It is possible that the flow of the program may be interrupted by some external event such as lightning, testing back-up generators or some other anomaly on the AC or Sensor input that may cause the flowmeter to crash or lockup. Turning power OFF and waiting approximately 10 seconds before turning the meter back ON may correct/unlock the meter. If not, it may be necessary to perform a RESET using the SELECT or SHIFT button mentioned above, RESETTING THE FLOWMETER. You should only need to do a FACTORY DEFAULT reset and then reprogram the flowmeter. You should not need to reset the totalizer or data log.

In extreme cases, it may be necessary to do a HARD Reset by first turning power OFF to the flowmeter and then removing the 3 volt clock/memory coin battery from its holder for about 1 minute. This will cause a loss of all data, including totals and data logging.

Reinstall the coin battery (note polarity) and do a power up reset using the SHIFT button as mentioned above. Proceed to reprogramming the meter. Set the clock and date and reset the totalizer and data log when asked.

Using The PDS-360 FLOWCHART

OPERATING INSTRUCTIONS

When power is first applied, the PDS-360 flowmeter will run through its POWER-UP windows. It should display 2 windows indicating name of manufacturer, model number, type of meter and the software revision number. The process takes a few seconds and will then enter the RUN MODE. The flowmeter will display the window that was ON (selected) prior to turning power 'OFF'. To select or scroll through the RUN MODES, use the UP/DOWN buttons. Each press of the button takes you to the next window. Selecting any of the RUN MODES will not affect the 4-20 mA. output or any of the programmed settings. The flowmeter begins monitoring flow automatically.

To enter the **PROGRAM MODE**, press the SELECT button. You will be asked **GO TO PROGRAM MODE?**. Press 'YES'. You will be asked for the **PASS CODE** before you can enter into the **PROGRAM MODES**. The pass code is 0000 when it leaves the factory and will remain this until you change it. Press SELECT. If you like to change the code at this time, use the SHIFT, UP and DOWN buttons to enter your new pass code then press SELECT. This stores your new code. You now have access to the program section. If the incorrect pass code is entered, you will be returned to the RUN MODE. **REMEMBER YOUR PASS CODE!!!**

Once you entered the **PROGRAM MODE** you can scroll through it by pressing the SELECT button. The SELECT button performs three functions: 1] NO, 2] ENTER and 3] NEXT WINDOW. Use the SHIFT, UP and DOWN buttons to change the values in each window as needed. The DOWN button is used to select YES when data values are not displayed. The Programming Flowchart will guide you through the many features and functions available to you. A brief explanation for each window is provided in the flowchart.

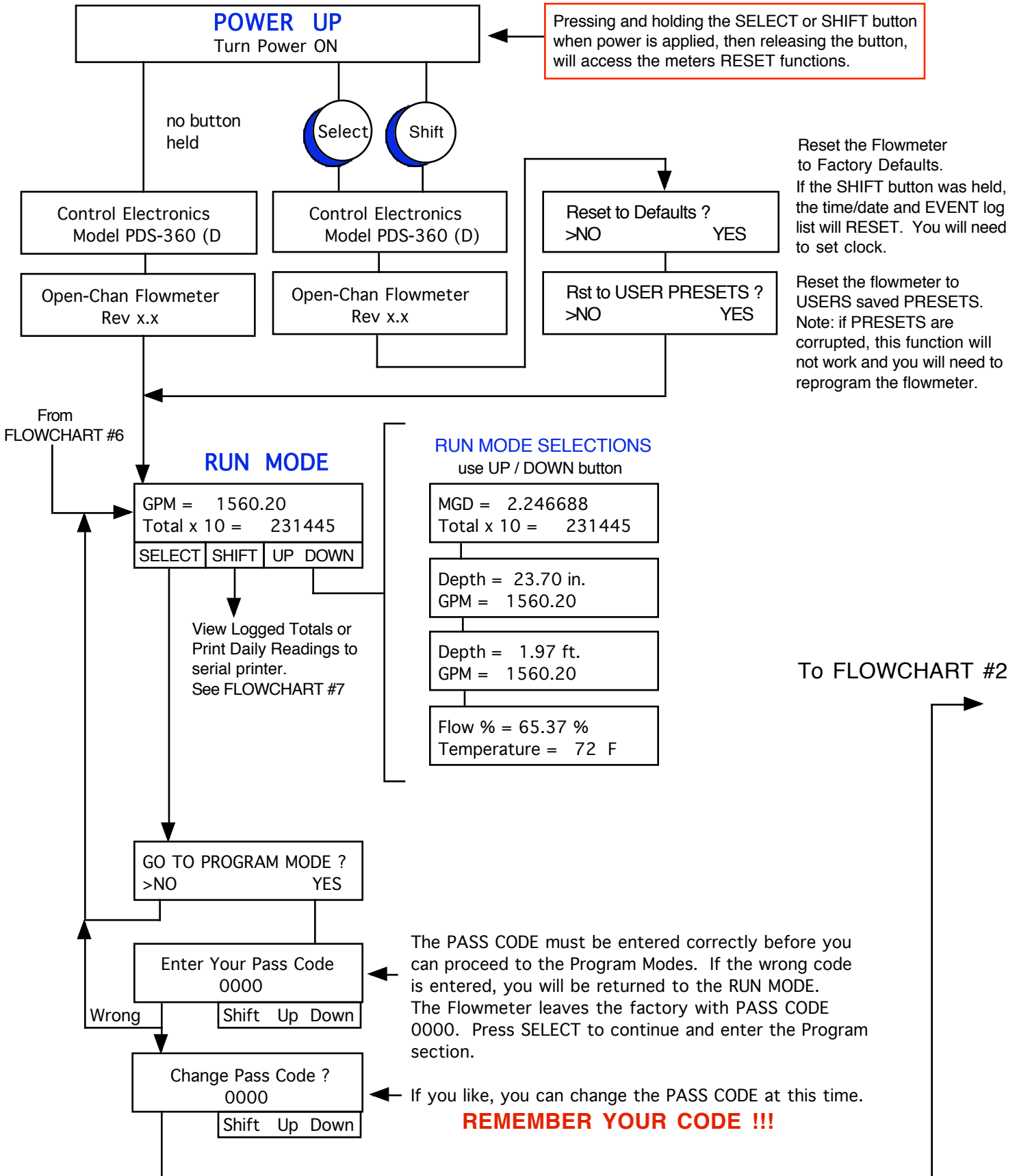

Note: Shadowed Windows must be set by the user. All others are optional.

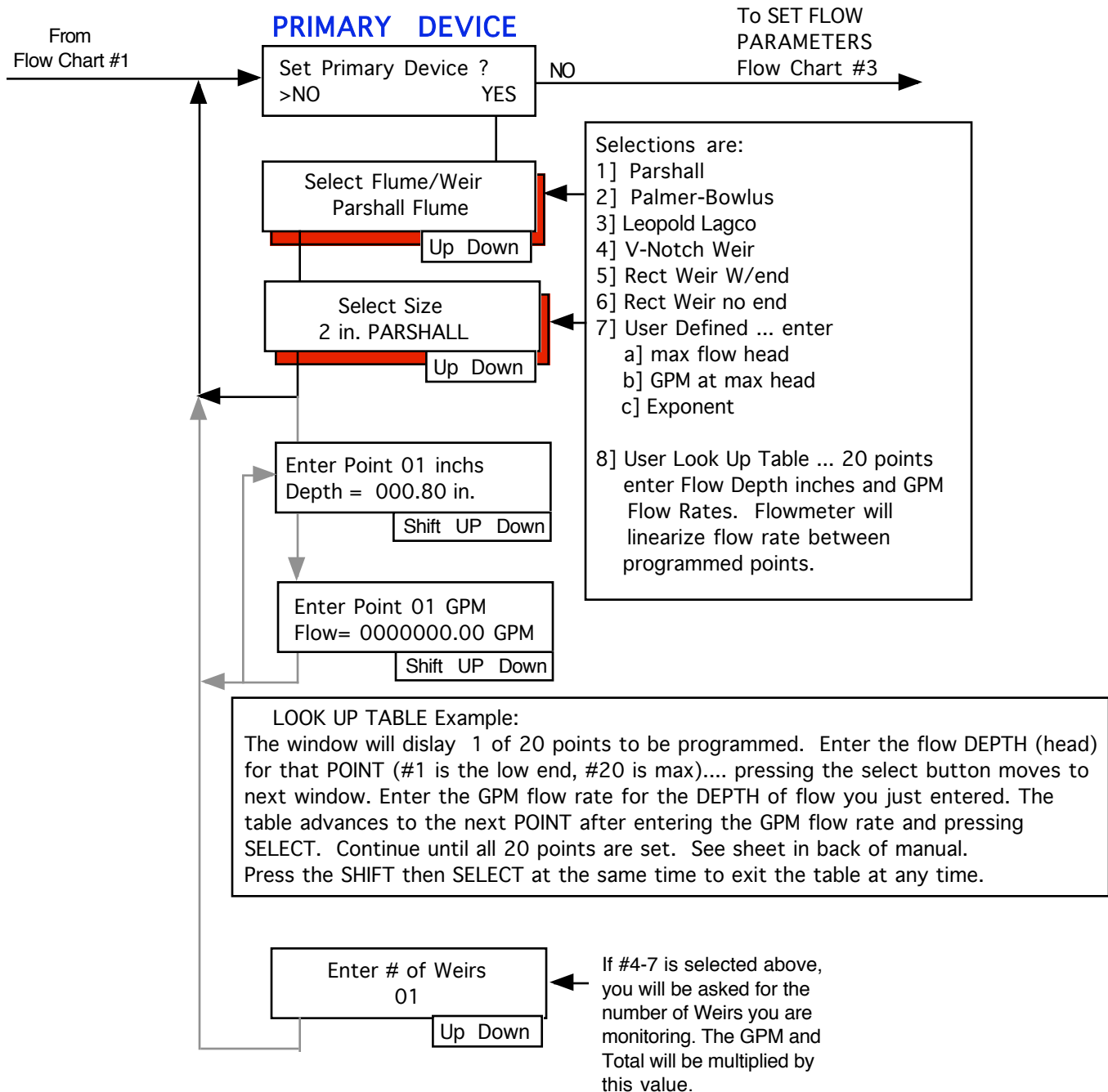

Select the Primary Device you are monitoring or use the USER DEFINED or USER LOOK UP TABLE to enter your own flow curve. USER DEFINED uses the ratiometric method to calculate flow. You will most likely need the flow chart for the flow device your using to look up the required information to enter in the programming. USER LOOK UP TABLE is a 20 point look up table with DEPTH vs. GPM flow parameters programmed. All others use the accepted equation for the selected Flume/Weir and do not require you to enter specific information from a flow chart.

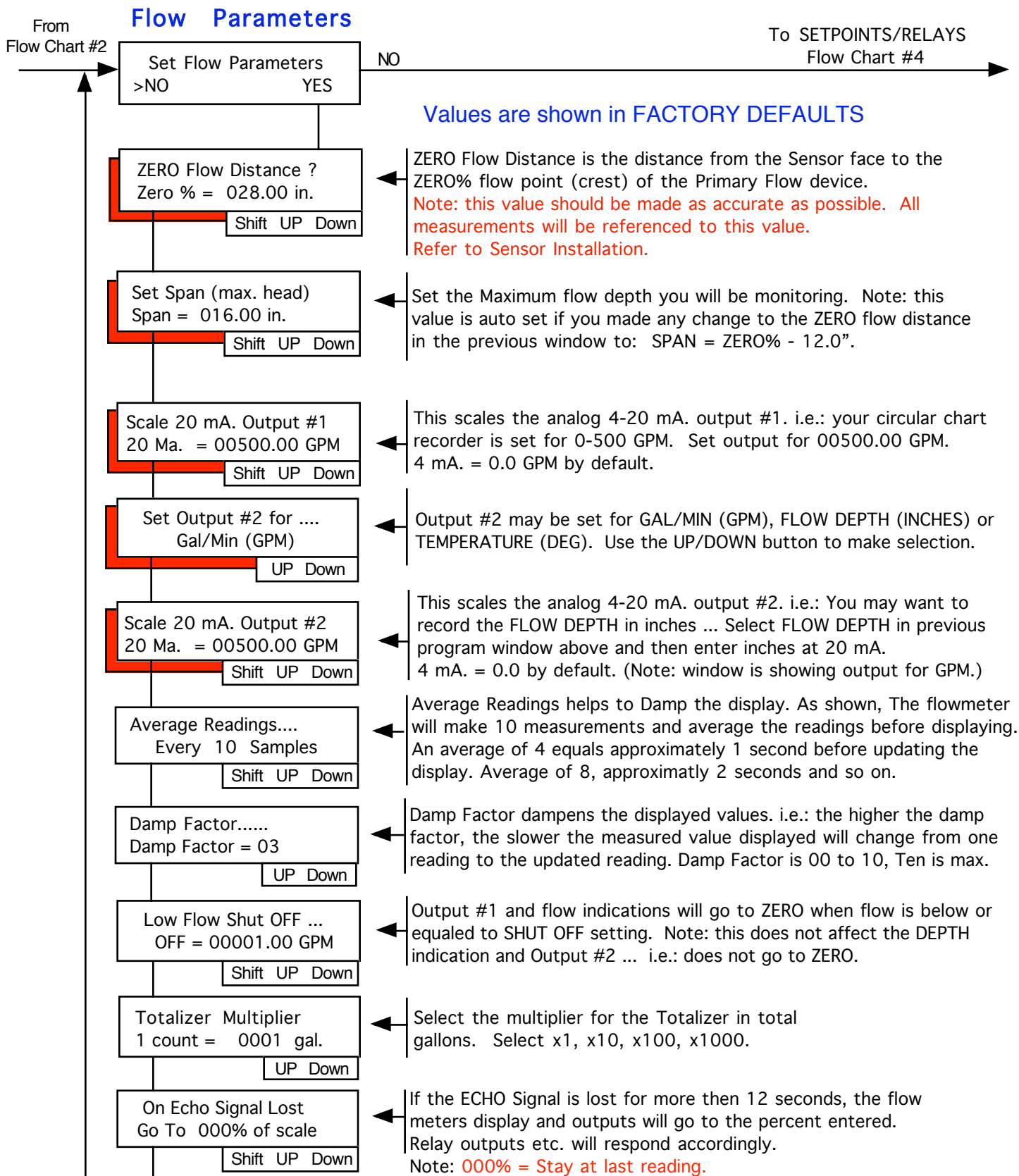

Note:
RED shadowed Windows indicate that these parameters MUST be set by the operator to calibrate the flowmeter to the application. All other settings are optional to the user.

RELAY OUTPUTS - N/A on 360DX

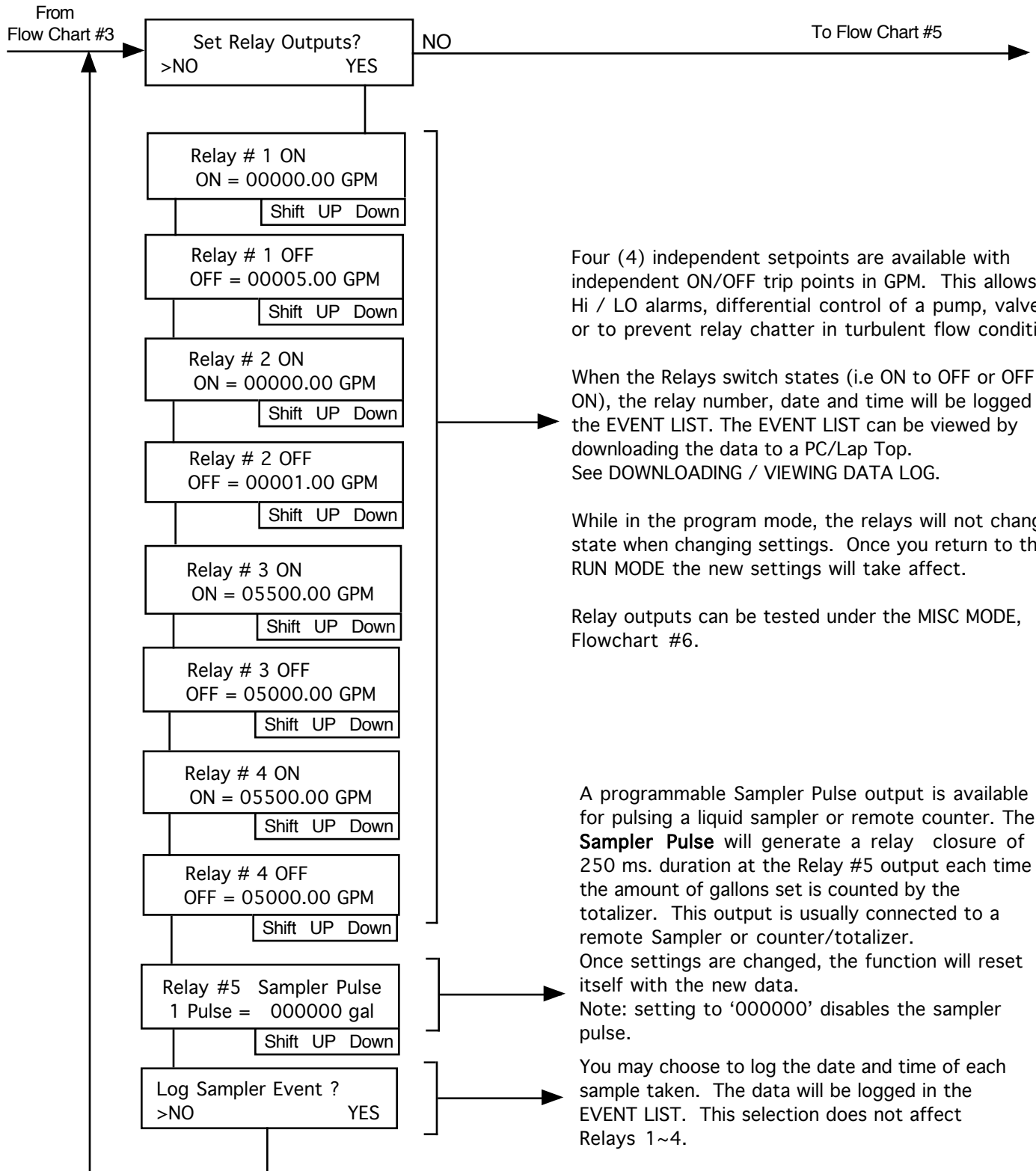

Four (4) independent setpoints are available with independent ON/OFF trip points in GPM. This allows for Hi / LO alarms, differential control of a pump, valve etc. or to prevent relay chatter in turbulent flow conditions.

When the Relays switch states (i.e ON to OFF or OFF to ON), the relay number, date and time will be logged in the EVENT LIST. The EVENT LIST can be viewed by downloading the data to a PC/Lap Top. See DOWNLOADING / VIEWING DATA LOG.

While in the program mode, the relays will not change state when changing settings. Once you return to the RUN MODE the new settings will take affect.

Relay outputs can be tested under the MISC MODE, Flowchart #6.

A programmable Sampler Pulse output is available for pulsing a liquid sampler or remote counter. The **Sampler Pulse** will generate a relay closure of 250 ms. duration at the Relay #5 output each time the amount of gallons set is counted by the totalizer. This output is usually connected to a remote Sampler or counter/totalizer. Once settings are changed, the function will reset itself with the new data. Note: setting to '000000' disables the sampler pulse.

You may choose to log the date and time of each sample taken. The data will be logged in the EVENT LIST. This selection does not affect Relays 1~4.

COMMUNICATIONS / DATA LOG - N/A on 360DX

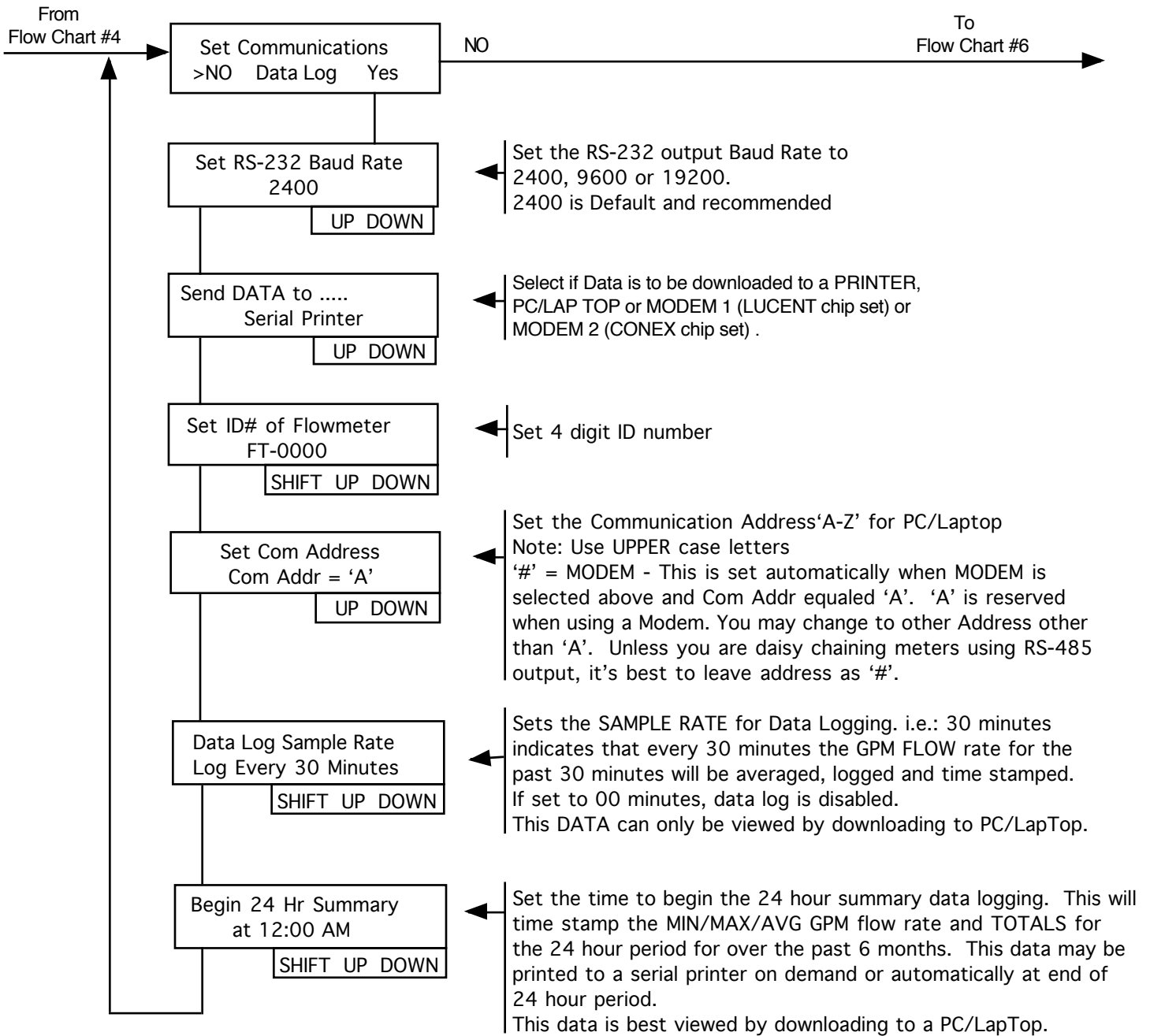

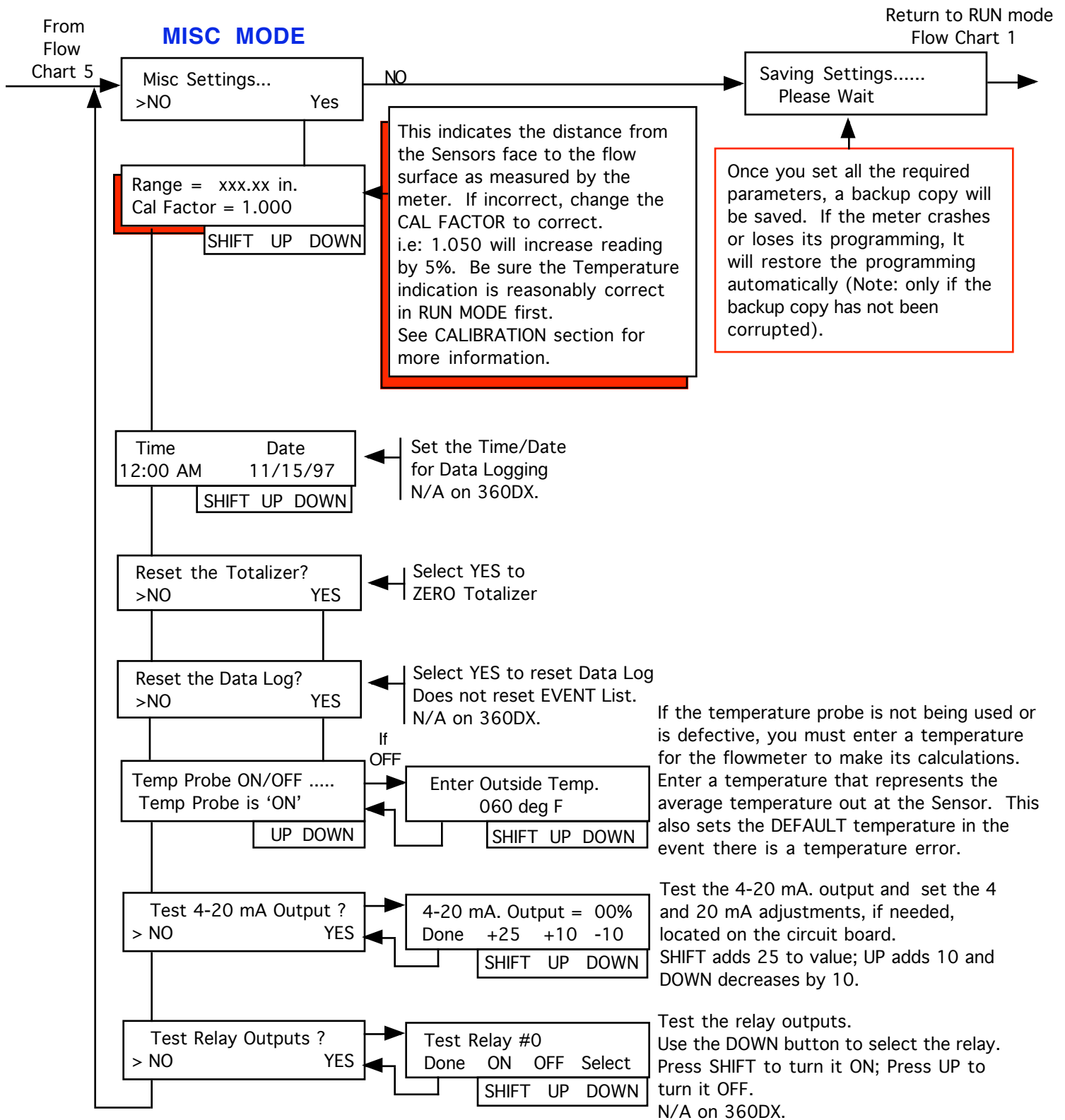

N/A on 360DX

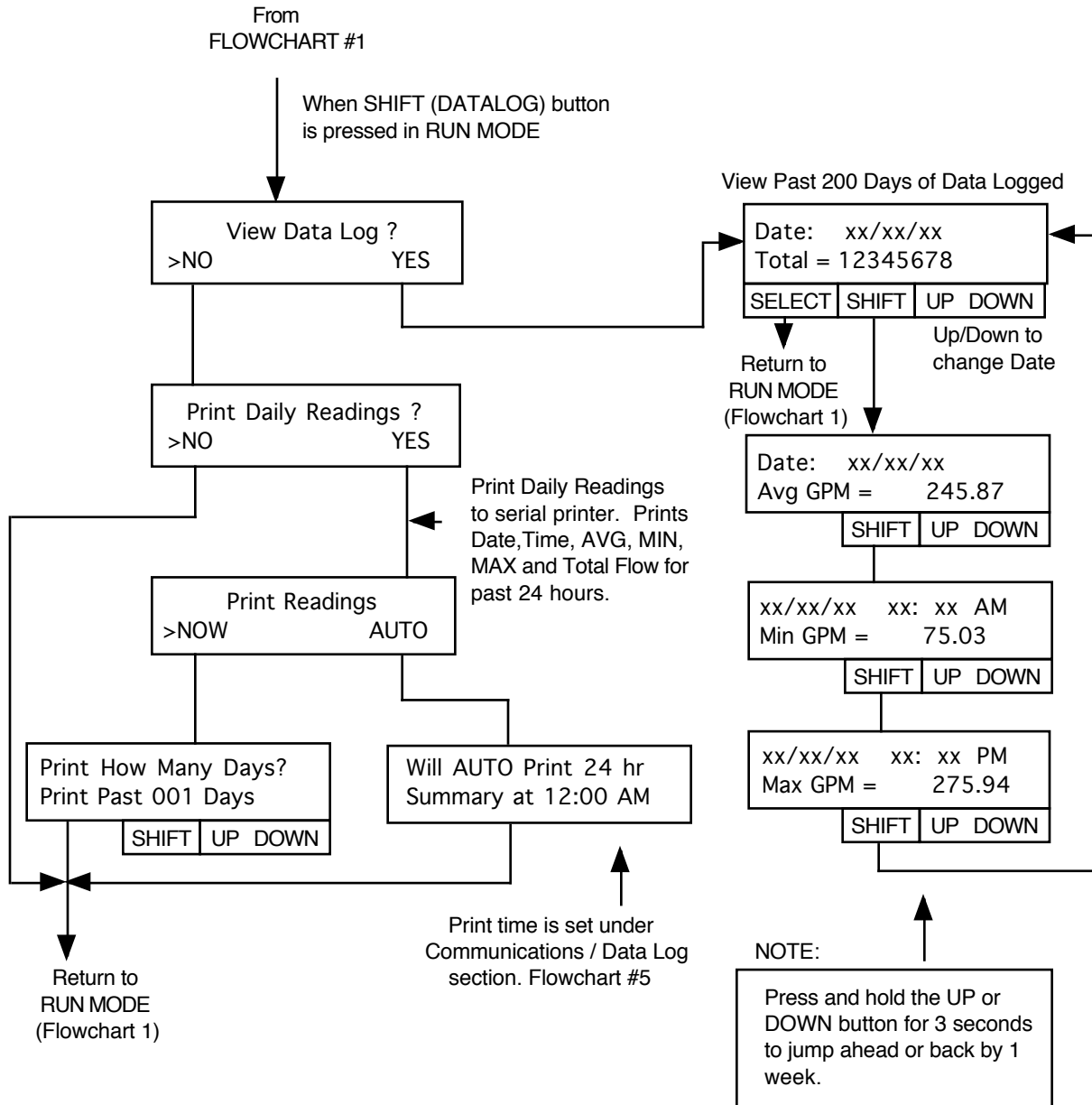

Display Warnings - 360 and 360DX systems

Echo Signal Lost!
Check Sensor & Wires

Temperature Error!
Check Probe & Wires

Check Sensor Wiring!
Echo & Temp ERROR...

If the PDS-360 or 360DX system loses the ECHO return signal or senses a temperature error (greater than 140° F) or both, 1 of the 3 warnings will be displayed. If this occurs, check the sensor mounting, installation and wire connections / splices for damage or sensor misalignment.

Other causes of error could be defective sensor and/or temp probe, malfunction of ultrasonic card or other. Call Factory for assistance.

Press any button to remove warning.

Using the RS232 Communication Output Port (N/A360DX)

The Operator may choose to communicate with the flowmeter using their PC/Lap Top computer or Modem to download the logged data for further viewing and analysis or view the present status of the flowmeter. This may be accomplished by using any standard communication software package such as Microsofts WINDOWS HYPER-TERMINAL. All data downloaded is in ASCII format. Each line of data is terminated by a CR (carrage return) and line feed. Downloading of flow data may be initiated from the flowmeter using the PRINT function (see FLOWCHART #7) or by the PC/ Lap top computer. Connect your communication cable to the RS-232 terminal barrier or RJ11 modular jack (located at bottom right corner of circuit board) and your PC communication port (COM 1 or COM 2) as indicated or Modem (see drawing 100-05).

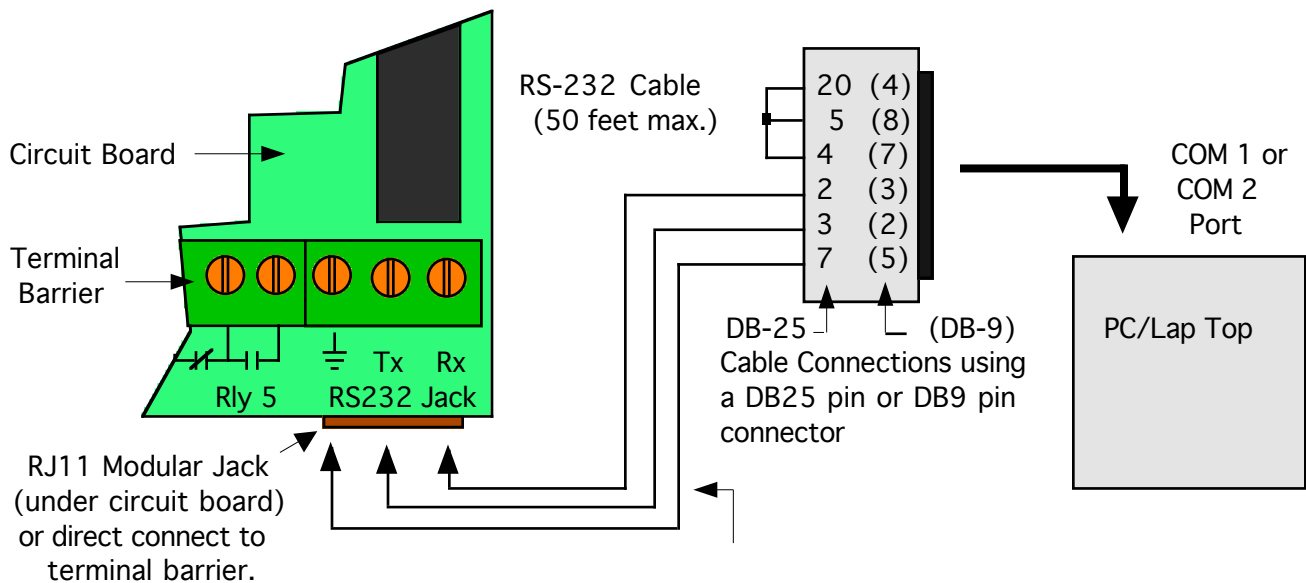

Make the connections shown to a 25 pin or 9 pin cable connector/socket as shown. An RJ11 modular cable with 9 pin adapter to COM 1 or COM 2 port on PC/Lap Top may also be used. Max imum cable length not to exceed 50 feet.

In order to successfully download data, you must first match the communication settings in both the flowmeter and the PC. The flowmeter sends data in one of three baud rates - 1200, 2400 (default) or 9600 baud. The baud rate is set in the flowmeter by the user under the **Set Communications** program section. You may set the flowmeter ID# at this time, the Com Address (default = 'A', suggest leaving as 'A') and whether data will be sent to a SERIAL PRINTER, PC/Lap Top or MODEM.

Saving To File

If you like to save the data to a file, you must first set your communication software in the PC to 'begin capture' (under HYPER TERMINAL 'TRANSFER' menu. See your PC/software owners manual for assistance). It is not necessary to 'capture' the data if you only want to view it on the PC/Lap top. You may set the 'begin capture' after the initial 'MENU' has been downloaded from the flowmeter and before making a MENU selection. When Download is completed, select 'Stop capture' under the 'TRANSFER' menu in HYPER TERMINAL.

Communication Settings Using A Modem

You will first need to open WINDOWS HYPER TERMINAL by selecting: START/PROGRAMS/ACCESSORIES/COMMUNICATIONS/HYPER TERMINAL. Open HYPER TERMINAL and select if necessary under file and properties... 'CONNECT USING' and your PC MODEM. Enter phone number etc. for the flowmeter location. (see drawing 100-05 for cable connections).

Communication Settings Using A Direct Connection to COM Port

Same as above (Using A Modem) except under 'CONNECT USING', select 'Direct COM 1 or COM 2', whichever you are connected to with your RS-232 cable. You should set the PC parameters to match the flowmeters baud rate, no parity, 8 bit, 1 stop bit, XON/XOFF disabled (no handshaking). (i.e. 2400,N,8,1)

IMPORTANT

It is necessary to disable all communication 'Flow Control' . Do Not use XON/XOFF or other hardware handshaking.

Using A Serial Printer

Select SERIAL PRINTER under **Set Communications Send DATA to....** This mode is used to send data to a serial printer and is fairly slow, because a 2 second delay is performed by the flowmeter for each line sent to allow the printer time to print the line. Be sure to set the serial printers baud rate to match the flowmeters. See drawing 100-06. Printing of data is initiated from the flowmeter by pressing the SHIFT (Data Log) button while in the Run Mode. (See FlowChart #7).

To Initiate Download from a PC/Laptop or Modem:

Connect the communication cable to the RS-232 connector on the Flowmeter to your PC/Lap Top COM port if not using a MODEM. Open your PC communication software (i.e. HYPER TERMINAL), then:

1] If Direct Connection...

type SHIFT-'A' (= com addr as set by user - 'A' is default) to get the flowmeters attention.

If using a MODEM...

dial up the flowmeter first. Once connection is made, type SHIFT-'#' or Com Address programmed other than 'A'. 'A' is reserved when using a MODEM.

2] Flowmeter should respond with a greeting, model number and a short menu.

```
Hello!  
Control Electronics PDS-360 Flowmeter  
Enter Download Selection Type....
```

```
1] 24 Hour Daily Flow Summary  
2] Data Entries  
3] Present Status  
4] Data Entries with Plot  
5] Event List  
6] Reset Data Log  
7] Terminate Communication  
8] Show Menu  
Hit SPACE Bar to interrupt Download.  
Your Choice .....  
>
```

Once communication is established, you may select type of download by typing the number of the selection.

Selection 1: will download the past 30 to 200 days 24 hour flow summary with DATE, MIN/MAX GPM with TIME, AVG GPM and TOTALS.

Selection 2: will download data entries as logged, time stamped. This download could take a few minutes depending on baud rate and data size.

Selection 3: this will display the present flowmeter status. GPM, Flow Depth, Temperature and Total will be displayed.

Selection 4: same as number 2, but with plot.

Selection 5: will download the event list.

Selection 6: resets the Data Log and terminates communication with flowmeter.

Selection 7: terminates communication with flowmeter only. Modem is terminated under HYPER TERMINALS 'CALL' menu.

Selection 8: Show MENU again.

Please note:

- 1] while the flowmeter is downloading data, the flowmeter may stop flow measurements until download is completed.
- 2] Hit 'SPACE' bar at any time to interrupt the download.
- 3] All downloads begin with the most recent data.
- 4] All downloads begin with a header indicating model#, ID# and date.
- 5] Pressing any key on the flowmeter will terminate communication.

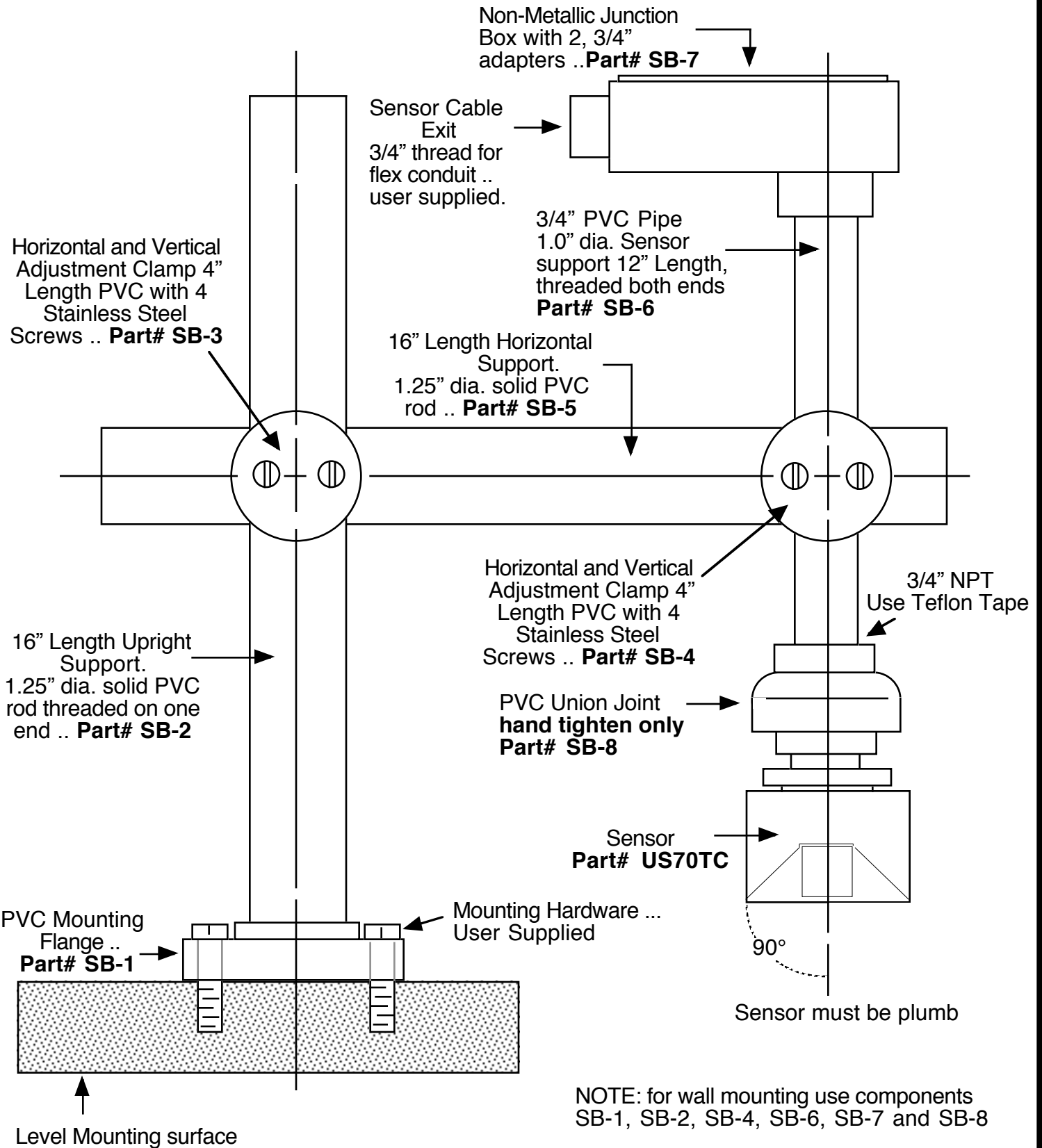

PVC Sensor Mounting Kit
Part# SBK-2
 Sensor ... order separately

Control Electronics, Inc.

PVC Sensor Mounting Bracket

Date: 10/12/06

Rv 2

Drawing 100-04

3/4" PVC Union Joint For Mounting US70TC Sensor to PVC Sensor Mounting Bracket.

- 1] Slide part 'A' onto 3/4" PVC Sensor Mounting Pipe and screw mount Part 'B' to pipe. Use Teflon tape on threads. Note: make sure 'O' Ring does not fall off..
- 2] Screw mount part 'C' to US70TC Sensor. **Handtighten ONLY.**
- 3] Slide Sensor cable through Union Joint and 3/4" PVC mounting pipe and tighten part 'A' to part 'C'.

See Sensor Mounting Bracket for further detail.

Union Joint is recommended for easy connection to and removing from PVC sensor bracket. Use of the Union Joint will prevent the sensor cable from being twisted in the 3/4" PVC pipe and provide decoupling of sensor vibration from mounting bracket.

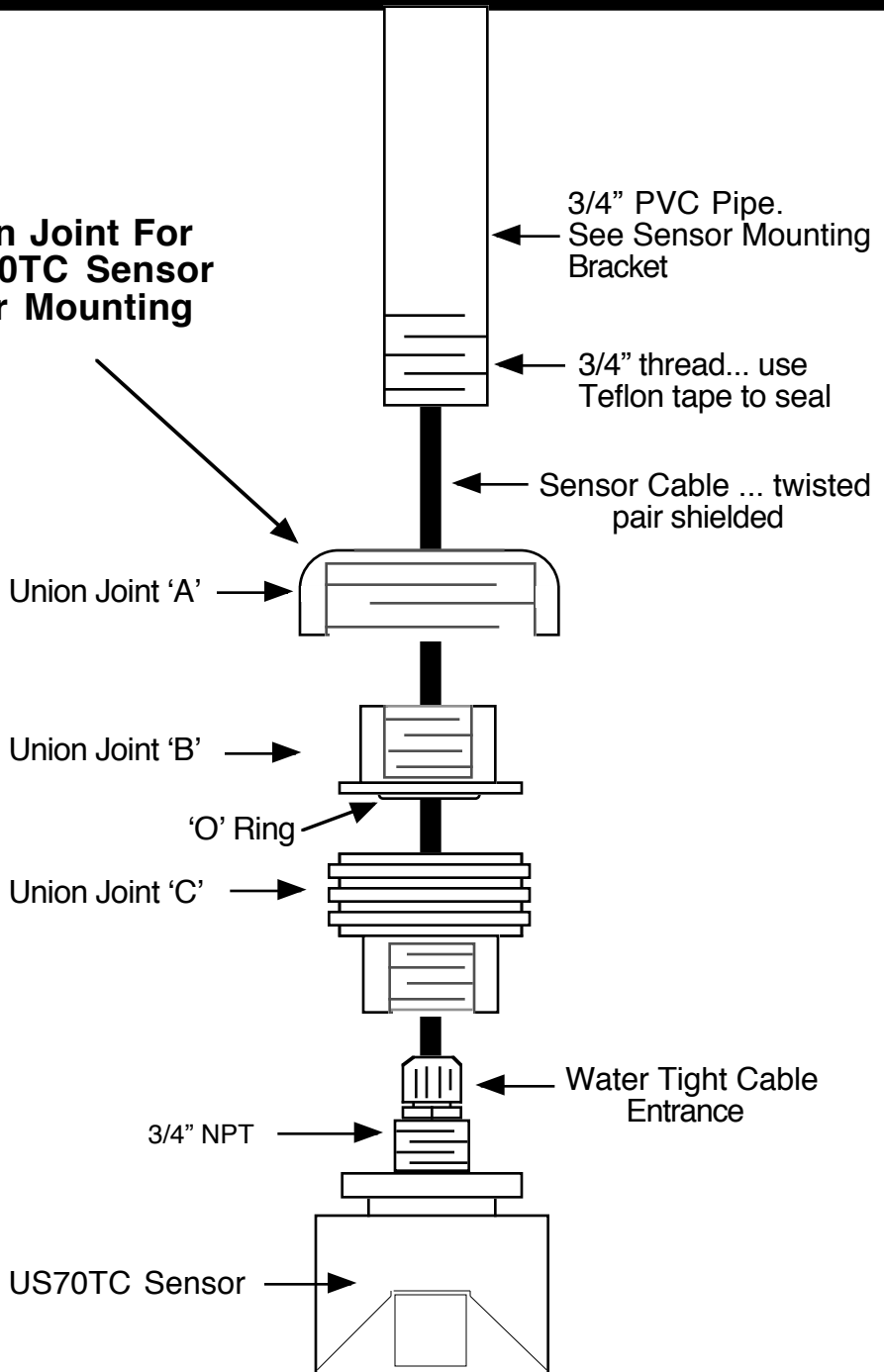

Control Electronics, Inc.	
Union Joint To Sensor Detail	
Date: 9/01/06	Drawing 100-08

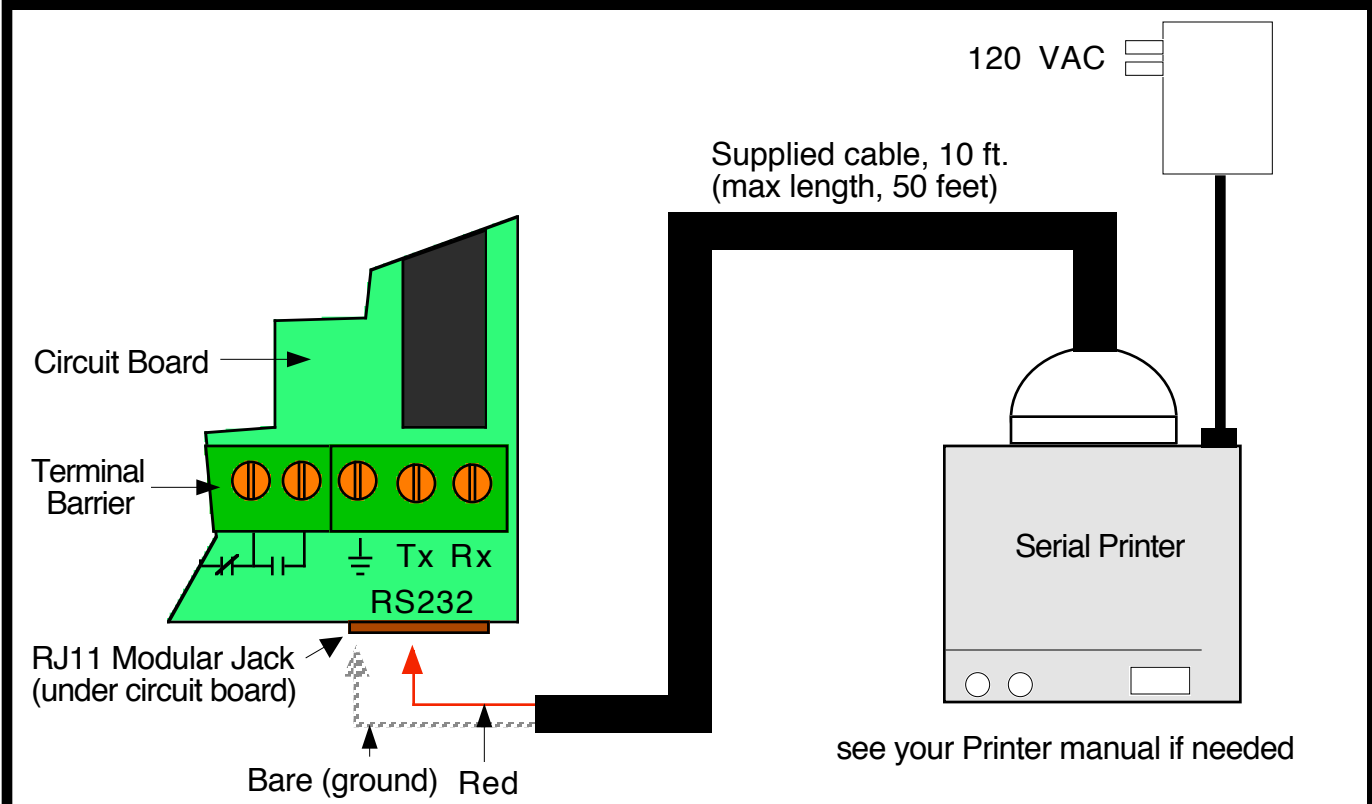

Make connections shown with supplied cable

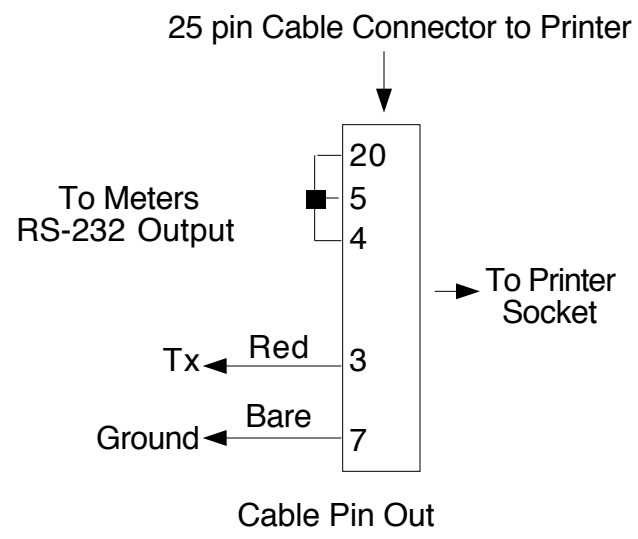

Control Electronics, Inc.	
PRINTER Connection	
Date: 1/1/05	Drawing 100-05

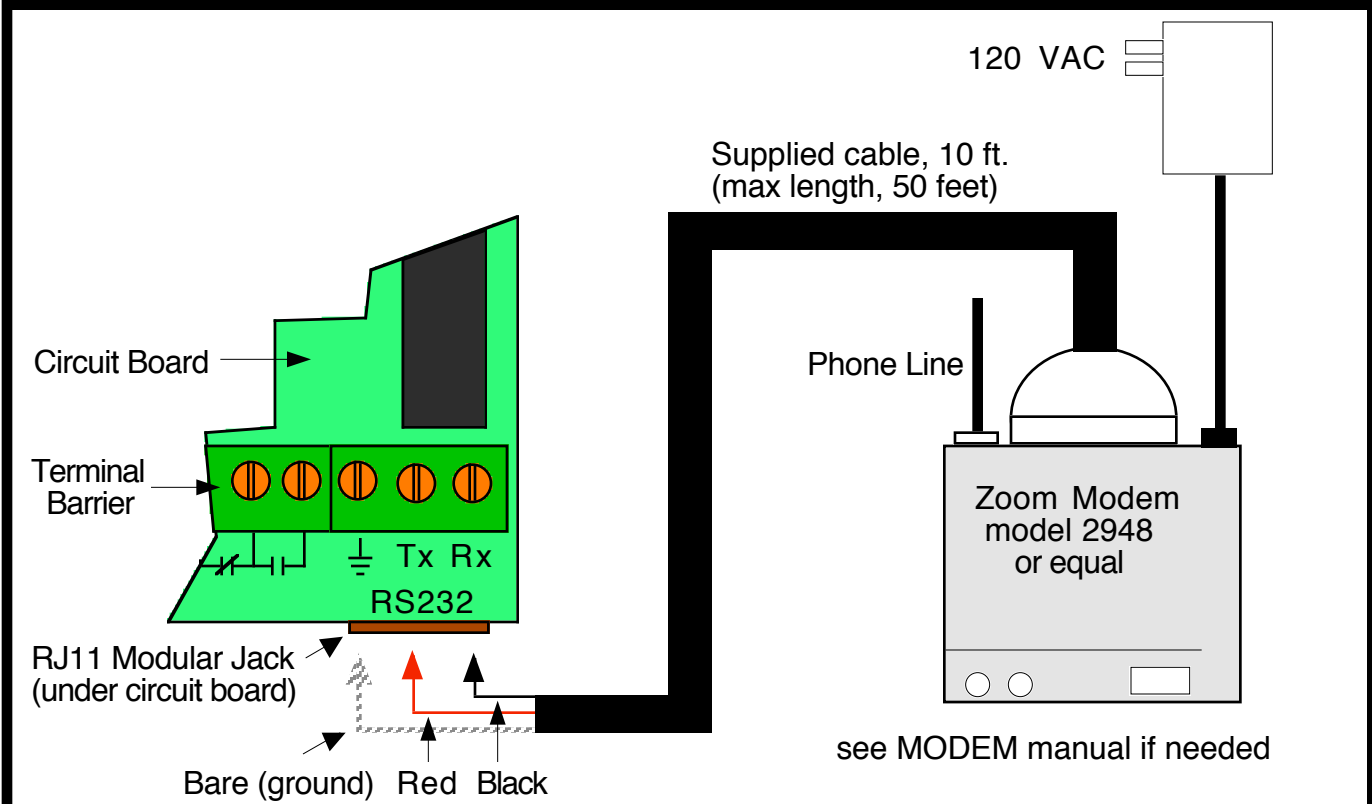

Make connections shown with supplied cable

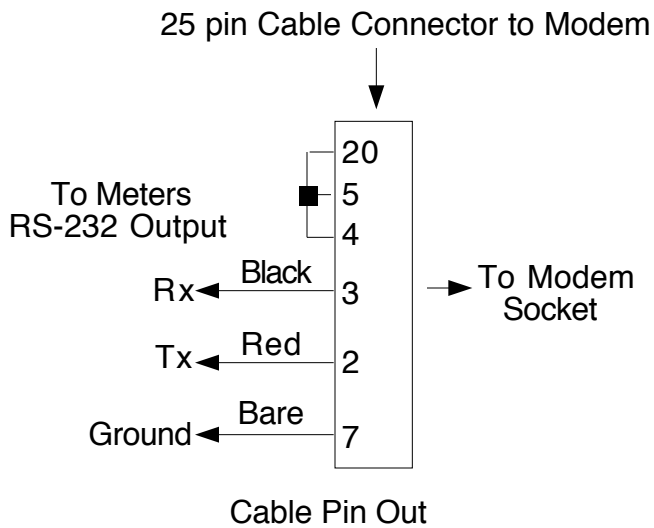

The Meter has been programmed to operate with most modems. Some modems may not function properly.

Connect as shown and turn ON the modem. Select MODEM under DOWNLOAD DATA TO in programming of the meter. See FLOWCHART for assistance.

Use Microsofts HYPER TERMINAL for WINDOWS to dial up modem. Once modem answers and connection is made, the dial-up window will close. Type 'SHIFT-#' or selected COM ADDRESS (other than 'A') to download meters MENU.

See USING THE RS-232 OUTPUT in meters manual.

Control Electronics, Inc.	
MODEM Connection	
Date: 1/1/05	Drawing 100-06

PDS-360 Troubleshooting Guide

Symptom	Cause	Check or Try
<p>#1 No display No Display backlighting</p>	<p>No Power Defective Display</p>	<p>Check power circuit breaker and wiring ON/OFF switch on main circuit board Ribbon cable not secure 0.5 amp fuse on main circuit board</p>
<p>#2 Keypad Does Not Respond</p>	<p>Ribbon Cable Lightning or Power surge</p>	<p>Check ribbon cable Turn unit OFF, wait 10 sec. turn back ON RESET and Reprogram meter</p>
<p>#3 4-20 mA. Output Not Functioning 4-20 mA. Output Indicates Max All The Time (see #9 below) Output Not Same As Display</p>	<p>Defective Wiring Defective Output and/or Lightning Damage Not Scaled Correctly</p>	<p>Check wiring and polarity Disconnect output wires and check 4-20 with current meter. If OK, receiver or wiring is problem. Replace Q1 and/or Q2 (2N3904 transistor) and U1(LM324 IC) on main circuit board. Go to programming, 'SCALE 20mA OUTPUT' and 'TEST ANALOG OUTPUT'</p>
<p>#4 Display Does Not Change or Update</p>	<p>Processor Crash Lightning or Power Surge</p>	<p>Turn unit OFF, wait 10 sec. turn back ON RESET/Reprogram meter</p>
<p>#5 Pass Code Lockout</p>	<p>Wrong Code Code Corrupted</p>	<p>Call Factory for alternate code Provide product SN# on Printed Circuit Board. Call (610) 942-3190</p>
<p>#6 Display Says 'ECHO LOST, Check Wiring</p>	<p>Sensor NOT LEVEL Accoustic Signal Path Obstructed Defective wiring or wrong cable type Defective Sensor</p>	<p>Check sensor mounting for plumb Check for signal path obstructions Check wire splices for break or short - Do not solder or use wire connectors at splice - use wire nut and electrical tape Test sensor back at the meter to by-pass cable run ... replace sensor and/or PC-548 transmit/receive circuit card if needed.</p>

LOOK UP TABLE FLOW DATA



Control Electronics, Inc.
P.O. Box 330
Brandamore, PA 19316
USA

Phone: (610) 942-3190
Fax: (610) 942-3672
e-mail: cei@controlelectronics.com

Model No.: _____
Serial No.: _____
Date: _____
Data Source: _____
Device Type: _____

Customer: _____
P.O.#: _____
Sales Rep: _____

Programmed Flow Data

POINT	INCHES	GPM	FEET	MGD
0				
1				
2				
3				
4				
5				
6				
7				
8				
9				
10				
11				
12				
13				
14				
15				
16				
17				
18				
19				
20				

NOTE

- 1] Flowmeter will linearize values between points.
- 2] LOOK UP Data may be changed at any time.
- 3] Flow Data entered should not be less than the proceeding programmed point.
- 4] Flow DEPTH greater than POINT 20 value will not show any increased flow rate. Table should be reprogrammed.
- 5] Use more POINTS to represent the sharpest curve... usually at bottom of curve.

COMMENTS